

The Magic Mushroom Growers Guide

Version 3.2 (3.22 by Erowid)

Widely acclaimed as the best and most comprehensive growing guide for the first time cultivator anywhere on the web. You be the judge!

original source: https://www.erowid.org/plants/mushrooms/mushrooms_mmkgg.shtml

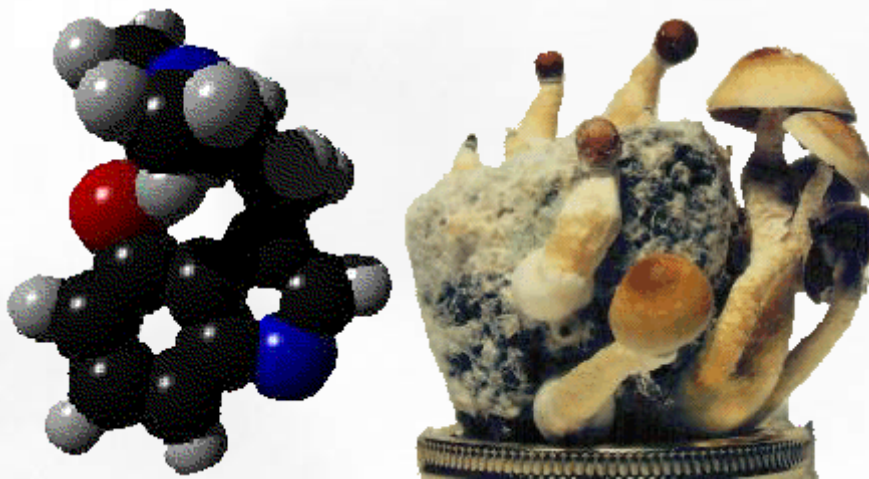

This document may be freely copied and distributed so long as the following conditions are met:

- Any copies of this document must include this notice.
- This document must only be distributed in an unaltered and complete form.
- This document can not be distributed for profit.

This document provides complete directions for cultivating psilocybin mushrooms in your home. The strain this guide is intended to help you grow is *Psilocybe cubensis* (Amazonian strain) mushrooms. It is the intent of this document to enable the first time grower to succeed at a minimal cost and with a minimal amount of effort. This growing guide is the only reference you will need. After a person has completed the entire cycle successfully, later generations of mushrooms can be grown with even less cost and effort. The initial cash outlay will be well under \$100 for a fully automated shroom factory. Subsequent crops can be produced for several dollars with expected yields of several ounces of dried mushrooms.

Table of Contents:

What has changed since version 3.1

Credits to those who have gone before us

Format of this Document

Overview of the Procedure

Preparation of the Substrate

Construction of the Terrarium

Poor Man's Terrarium

Basic Growing Chamber

Method 1: Hand Spraying

Method 2: Using a Fish Tank Bubbler

Method 3: Using an Ultra Sonic Humidifier

Checking out the Ultra Sonic Humidifier Setup

The Growing Cycle

Drying and Preservation of the Mushrooms

Dosage and Various Ways to Ingest

Mushroom Juice

Mushroom Tea

Mushroom Soup

Mushroom Pizza

How to Get a Spore Syringe

Sources for a Spore Syringe

Sources for Spore Prints

How to Make a Spore Syringe

How to Make a Spore Print

Combination of Spore Print and Preparation of Inoculant

The Author's First Trip

Bulk Substrate Growing

Where to find Difficult Items

Brown Rice Flour

Ultra Sonic Humidifiers

Vermiculite

10 cc. Syringes

Providing Feed Back and Getting Questions Answered

Index of Adaptations

Adaptation-1: Use of Big Substrate Jars

Adaptation-2: Use of a Pressure Cooker to Sterilize

Adaptation-3: Tight Packing of Substrate to Slow Colonization

Adaptation-4: Injection at Only 1 Site

Adaptation-5: Large amounts of Inoculate

Adaptation-6: 80 Degree Colonization Temperature

Adaptation-7: More Oxygen for Colonization

Adaptation-8: Taking the Rice Cake Out of the Jar Before it is 100% Colonized

Adaptation-9: Waiting to Remove Rice Cake From the Jar

Adaptation-10: Checking Out Terrarium Prior to Removing Rice Cake

Adaptation-11: Use of a Coleman Cooler instead of a Styrofoam Cooler

Adaptation-12: Adding a Humidity Gauge to the Terrarium

Adaptation-13: Use of Fish Tank Heater to Raise Humidity

Adaptation-14: Use of Angel Hair to Raise Humidity

Adaptation-15: Supporting Extra Terrariums with the Ultra Sonic Humidifier

Adaptation-16: Use of an Ice-Pak to Initiate Fruiting

Adaptation-17: Adding Moisture to the Rice Cake

Adaptation-18: Continued Drying of Mushrooms During Storage

Adaptation-19: Reducing Output Of Ultra Sonic Humidifier

Adaptation-20: Providing a Moisture Reservoir in the Substrate

Adaptation-21: Use of a Timer to Control Suspended Water Droplets and Stimulate Fruiting

Adaptation-22: Use of a Home Made Brown Rice Flour

Adaptation-23: Lowering the Contamination Rate by Presterilization

Adaptation-24: Using a 2 1/2 gallon water jug for filtering

Adaptation-25: Insuring the Sterility of Caps Used for Spores

Adaptation-26: Producing a clean spore print from a questionable cap

Revision History

What has changed since version 3.1

Following is a list of changes made to the document.

3.22 : 2005 Dec : by Erowid.org :

- Typo fixes on suggestion of reader.

3.22 : 2005 Nov : by Erowid.org :

- Removed PF address on suggestion of reader. PF's arrest and guilty plea suggests it is no longer appropriate to send money to the old PF address.

3.2 : 1996 : Primary Author

- Version number was changed from 3.1 to 3.2
- Change pictures in opening.
- Suggest ways to get help and provide PGP public key for private messages.
- Poor Man's terrarium setup.
- Bulk growing.
- Cris Clays email address and such.
- Link to <http://www.xs4all.nl/~psee/> as a spore seller.
- No more packing of the substrate.
- Vacuum cleaner instead of hair dryer.
- Link to PF's pages.
- Timer stuff.
- Arrowhead Mills no longer sells brown rice flour as a mail order item.
- Caution about jars sitting flat in boiling pan.
- Low humidity cap appearance.
- Sealing a cake in a jar to reduce contamination risk when growing for spores.
- Changing plates after start of spore print for lower contamination risk.

Credits to those who have gone before us

The procedures detailed in this document borrow heavily from past innovators. In particular, much research was done by a company in Seattle, Washington called Psylocybe Fanaticus which was instrumental to the viability of this innovative and elegant procedure for the novice cultivator.

Psylocybe Fanaticus sold a Technology Report called the PF Tek. Normally, growing Psylocybe mushrooms is next to impossible for a beginner. However, the PF process is a breakthrough and virtually guarantees that the beginner will succeed.

The PF Tek is the foundation for this document. The main purpose for this document is to detail the various ways the PF Tek can be adapted to various needs of the home cultivator.

[Note: Psylocybe Fanaticus is no longer in business and plead guilty to a crime involving the possession of psilocybin-containing mushrooms. See [PF's Encounter with the Law](#). This section formerly requested that readers send money to PF in thanks for his work, but the address has been removed.] Please treat this document as you would 'shareware software'. Try it out, and if it works for you, send \$10 and a thank you note to:

Psylocybe Fanaticus
XXXX removed XXXX

[Back to table of contents](#)

Format of this Document

How to use this document

The procedures detailed in this document are a mixture of mandatory and optional steps. The core document describes the basic procedure in its simplest form and at various points there will be possible adaptations that can be incorporated. In general, the adaptations will summarize what is required and the benefit to the cultivator in the event the adaptation is implemented. You should read the entire document before you attempt to implement the procedures described in it.

The first time you use the process you should follow the directions exactly and resist the temptation to innovate. Innovation without experience is the primary cause of failure. If you must innovate because you can not find a particular item or for some other reason, first check with someone that has experience to make sure you are not doing something crazy.

It is our intent to provide the first time cultivator with the knowledge to make informed decisions about the growing process for Magic Mushrooms. The cultivator can select some adaptations that are felt to be worthwhile and reject others that don't have sufficient merit for him. It's his choice, but he is still guaranteed that if he follows the directions he will produce a crop of mushrooms.

This guide is published as a single document to make printing easy and simplify acquiring a copy to your local machine. There are several GIF files that it references in the directory that you found this document. You need these also. You might want to check and see if there is a file called MMGG.ZIP or MMGG.TAR in the directory you found this document. If so, you can just get this one file and it will contain everything you need to obtain a local copy.

If you wish to examine an adaptation, simply click on it. When you're done looking at it, there will be two links. One back to the table of contents and one back to where the adaptation is used in the procedure.

One last note. A terrarium is required to complete the growing cycle. You can perform the steps to inoculate the culture jars and over the next few weeks build your terrarium. It takes time for the cultures to grow and this should provide you sufficient time to make a suitable terrarium if you are in a hurry to get started.

[Back to table of contents](#)

Overview of the Procedure

In order to grow mushrooms, a suitable substrate must be inoculated and colonized by the fungus. This step requires sterility because the substrate contains no preservatives and can be overrun by any mold or bacteria that is present. This first step takes place in canning jars prepared in your home's kitchen. It uses brown rice flour and vermiculite which are both readily available. A substrate is prepared, placed in the canning jars and sterilized with heat. After the jars cool, they are inoculated with a spore syringe. This phase of the cycle can be completed for less than \$25 and will produce enough substrate to yield many ounces of dried mushrooms.

After the substrate is inoculated, you wait until it is colonized completely by the fungus. Once the substrate is colonized completely by the fungus, sterility is less of a concern because the fungus is pretty much able to fight off invaders and the rice cake substrate can be removed from the jar. This typically takes between two

and three weeks to complete. At this point, the substrate is placed in a terrarium where high humidity is available to the fungus. While waiting for the substrate to colonize completely, no effort is required.

The terrarium is kept at around 90% humidity and the carbon dioxide that is produced by the fungus is constantly eliminated. Within a week of being placed in the terrarium, the rice cakes will start growing mushrooms. Within several weeks of being placed in the terrarium, the cultivator will have numerous mature mushrooms ready for consumption. The cakes continue to produce mushrooms until either the nutrients in the rice cake are used up or the moisture in the rice cake is depleted. Depending on how the cultivator chooses to implement the terrarium, more or less attention is required at this phase in the cycle. With the fully automated terrarium setup described later in this document, attention is only required every few days. Mostly, this involves picking mature mushrooms and adding water to the humidifier used in the setup.

It is very likely that the mushrooms will be produced faster than they can be consumed by the home cultivator once the cropping phase of the cycle starts. It is fairly easy to dry the mushrooms and preserve them for many months. In fact, some people prefer the dried mushrooms to their fresh counterpart. Being the master of understatement, let me state that they do not taste as good as mushrooms available in the grocery store. Occasionally, a sterile spore print from a mature mushroom needs to be generated if the cycle is to continue. This is used to produce a spore syringe to inoculate new culture jars. It is a little bit of effort and requires very careful, sterile procedures to be successful generating a spore print. Of course, this can be circumvented by simply ordering a new spore syringe. A 10 cc. spore syringe should be sufficient to inoculate a dozen jars of substrate. It is the cultivator's choice which path to follow for successive generations.

[Back to table of contents](#)

Preparation of the Substrate

Mushrooms are grown on a substrate of nutrients. Just as a common house plant is grown in a pot of soil, mushrooms can be grown on a cake of substrate material. The big difference is that the substrate must be free of competing bacteria and molds in order for the process to be successful. Any contamination of the substrate will result in failure of the process.

Materials needed:

- 1/2 pint canning jars [Adaptation-1](#)
- Vermiculite (from any garden department. K-Mart, Target, etc.) [Where to find](#)
- Brown Rice flour [Adaptation-22](#) (from a health food store --- No Preservatives!) [Where to find](#)
- Large pot with lid [Adaptation-2](#)
- Measuring cups
- Mixing bowl
- Hammer and small nail
- Spore Syringe ([Where to get a spore syringe](#))

The canning jars need to be tapered. This means that the opening of the jar is wider than the body of the jar. This is important because the fully colonized rice cake needs to be removed intact from the jar. You simply want the cake to slide out when the time is right. If you use a jar that is not in the following list, check to make sure the box says it is a tapered jar. The following jars are acceptable:

- Ball 1/2 pint jelly jars.
- Kerr wide mouth 1/2 pint canning jars.
- Ball regular mouth 1/2 pint canning jars.

Step 1:

Prepare the tops of the culture jars so that they can be in place, on the jars when inoculating the jars with the spore syringe. Part of the reason this system works so well in the non-sterile kitchen environment is the fact that the sterilized substrate is never exposed to air born contaminants. Get a small nail and use the hammer to poke 4 holes in the lid of each canning jar. See the following figure:

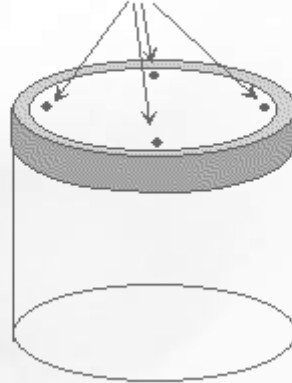
Location of holes in lid**Step 2:**

Decide in how many jars you are going to initiate cultures. The average terrarium that is built will hold 6 rice cakes but you may have some jars destroyed by contamination and some jars colonize more quickly than others. It is unlikely that every jar you prepare will be ready to be placed in the terrarium at the same time. The rice flour and vermiculite are cheap enough that it makes sense to do a dozen jars.

For each 1/2 pint jar mix **2/3 cup vermiculite** and **1/4 cup brown rice flour** in a mixing bowl. **Adaptation-23** When these ingredients are well mixed, add **1/4 cup of water** for each 1/2 pint jar you plan to prepare. If you are using 1 pint jars you need to double the recipe. Mix all of this stuff up well. This mixture is the substrate material that the fungus will consume and use for growth.

Step 3:

The next step is to fill each jar with substrate material. **Adaptation-20** This document used to suggest gently packing the substrate into the culture jars. It has been found that keeping the substrate as loose and full of air as possible is the best way to fill the jars. The jars will colonize faster this way. Incidentally, the faster the jar colonizes, the lower the risk that some competitor contamination will get a foothold and take over the substrate. **Adaptation-3** Fill each jar to within 1/2 inch of the top with substrate material. If you run out of substrate material, either mix up enough for one more 1/2 pint jar or cannibalize a jar to fill up the rest of the jars. This is important because you need to make sure the substrate is high enough in the jars for the spore syringe to inject spores into it.

Step 4:

The top 1/2 inch of the glass on each culture jar needs to be cleaned. No substrate material can be left on the glass above the compressed cake. First wipe it with your finger to get the bulk of the material off of it and then do a thorough job with a moistened paper towel. The glass needs to be spotless. The reason this is necessary is that bacteria and mold can use any material left there as a wick to infect the main substrate body.

Step 5:

Next, fill the top 1/2 inch of the each culture jar with vermiculite. This layer is pure, simple, dry vermiculite. Nothing else. Fill the jar level with the glass edge. This layer is a breakthrough pioneered by Psylocybe Fanaticus. What this layer does is insulate the sterilized substrate from any airborne contamination. This layer gets sterilized with the substrate later and airborne molds and bacteria can not (usually) get through it to contaminate the substrate. At the same time, it allows some gas exchange to occur. The fungus needs oxygen and gasses can filter through the vermiculite.

Step 6:

Now, place the jar lids in place. Normally, the jar lids have a rubber seal that is placed in contact with the glass of the jar. Traditionally the rubber seal is not placed in contact with the glass. It was placed on the upper

side of the lid. The reason was that people thought it would make too tight of a seal. This does not seem to be an issue. If you wish to follow tradition, place the rubber on the upper side of the lid. Screw the lid down tight. Note that you need to have the four holes poked in the lid in Step 1. Otherwise you can have real problems when you heat these jars up!

Step 7:

Next, place a piece of tin foil over the top of each jar and crumple it around the sides of the jar. This is to keep water drops from going in the four holes in the lid while the jar is being sterilized. If you poked your holes in the lid such that the sharp edges are pointing up, be careful not to rip or puncture the tin foil. If you need to, you can add a second or even a third piece of tin foil to make sure water will not drip into the holes in the lid.

Step 8:

Now the culture jars need to be sterilized. Place the jars in a large kitchen pot/pan and add water so that water comes halfway up the side of the jars. Bring the water to a slow boil and place the lid on the pot. From the time the water starts to boil, the jars need 1 hour to be sterilized. Water should not be bubbling and splashing all over the place. The jars should not be floating around in the water. The substrate in the culture jars has the right amount of water in it already. You do not want water leaking into the jars and changing the ratio. The jars should not sit flat on the bottom of the pan. Too much heat can transfer directly to the jars and cause a loss of moisture. You can place a wash cloth inside the pan and set the jars directly on the wash cloth to help prevent too much heat from transferring to the jars.

Step 9:

Let the jars cool slowly. Leave them covered in the pot/pan that was used to sterilize them. Let them cool completely. The jars need to be at or close to room temperature in order to inoculate. The spores will be killed if the jars are not cool enough when they are inoculated. It will take several hours to cool sufficiently. You may hear sounds as the jars cool. This is normal.

Step 10:

Now comes the good part. Inoculation of the culture jars. Assuming you have a viable, sterile spore syringe, you are now in a position to inoculate the cultures and start the first phase of the growing cycle. The needle of the spore syringe must be sterile. If your fingers or anything other than the lid or contents of the culture jars comes in contact with it, assume it is no longer sterile. If there is any doubt about its condition, use a cigarette lighter to heat the entire needle. Heat it until it glows red. Let it cool for a few minutes and squirt some of the solution out of the syringe.

Shake the syringe. Make sure the spores are mixed well within the syringe. This can be accomplished more easily if you pull the plunger back on the syringe to get a little air into the syringe.

Remove the tin foil from each culture jar as you prepare to inoculate it. Insert the needle of the syringe as far as it will go into a hole in the lid of the culture jar and get the needle to press against the glass. Examine the next figure for a simple diagram of how things should look. Inject 1/4 cc of solution at a site under each hole in the lid. [Adaptation-4](#). A total of 1 cc of solution for each jar. [Adaptation-5](#).

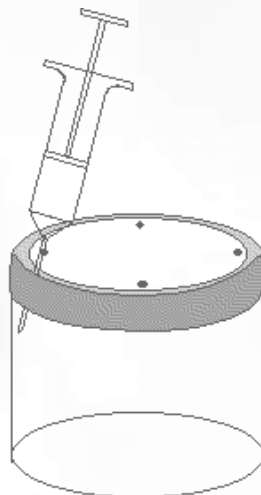

Innoculation of substrate

A 10 cc spore syringe is sufficient to inoculate a dozen jars if you inject slightly less than 1 cc in each jar.

Step 11:

This is the easy part. Put the culture jars in a dark place and wait. The fungus will first appear as little splotches of white fuzzy stuff at the inoculation sites. [Adaptation-6](#).



As the time goes by, the fungus will spread throughout the jar. Eventually, the entire surface of the glass will be covered with fungus. Typically, the bottom of the jar is the last area to be colonized. Be on the lookout for any contamination.

Any odd colors that might appear are contamination and the jar must be thrown out. Do not take any chances. If you think the jar might be contaminated, throw it out! Some molds and bacteria produce toxins that can kill you. Just because a mushroom is growing on the opposite side of the cake from the contamination does not mean you are safe. The mycelium network carries nutrients and moisture to the mushrooms from far away and can easily pick up the toxins and bring them to the mushroom. The fact that you are using this guide means you are not an experienced mycologist. You do not know which molds and bacteria are deadly. Do not take a chance.

The one exception to the previous statements is the mycelium will some timeschange from a bright white to a very pale yellow if it has water droplets touching it on the side of the glass. It is very unusual for any area that is colonized by the mushroom fungus to become infected while in the jar. The uncolonized areas of the substrate are usually significantly more prone to infection.

The above pictures show a typical germination and colonization cycle. If your spores are old, or the temperature is not optimum, or you did not mix the substrate very accurately you can easily add a week to the above time frames.

The cake must stay in the jar until the entire surface area is covered with mycelium. As the substrate gets more colonized, the growth slows down. This is a result of CO₂ building up and less oxygen being available for the fungus to consume. [Adaptation-7](#).

The cakes can not be taken out of the jars while there is still uncolonized substrate. [Adaptation-8](#).

Step 12:

Once a rice cake is fully colonized, it can be taken out of the culture jar. [Adaptation-9](#) At this point, there are no areas on the substrate that can easily be infected by competitor molds and bacteria. Once the mycelium is established, it can usually prevent other organisms from gaining a foothold and destroying the rice cake.

[Adaptation-10](#) Unscrew and remove the lid from the canning jars. Scrape all the loose vermiculite on the top of the substrate into the garbage. Take care not to gouge into the substrate material as this can leave areas open to infection. You do not need to get all the vermiculite off of the cake. In fact, the only reason to remove any of it is to keep the terrarium neat and orderly. Turn the jar up side down and slam it onto a table top. The rice cake should slide out of the jar. The rice cakes will typically shrink a little during the colonization phase of the process and will come out of the jars easily with a little tapping on a tabletop.

Step 13:

The rice cakes need to be placed into the terrarium. It is assumed that you have a fully functional and checked out terrarium setup at this point. This document contains all the information you need to prepare a terrarium. [Preparation of the terrarium](#).

You can handle the cakes but remember that the less you handle them and the more gently you handle them, the better off they will be. Also, you should wash your hands thoroughly and be sure to rinse with water just as thoroughly to remove any soap before touching the cakes.

If you have disposable sterile gloves available, it isn't a bad idea to use them. You can get away without using them, but they are a good idea. Contamination is the mycophile's worst enemy.

[Back to table of contents](#)

[The Growing Cycle](#)

[Construction of the Terrarium.](#)

Construction of the Terrarium

The main purpose of the terrarium is to provide the high humidity required for mushroom development. The rice cakes will live inside the terrarium during the cropping phase of the growing cycle.

There are four different setups described in this document. The first one is a very simple, minimal terrarium that works well, but can only handle one rice cake. The second two are based on work done by Psylocybe Fanaticus. They will hold more cakes than the first terrarium, but they still require attention several times a day.

I encourage you to choose the last option. This one uses the same growing chamber as Psylocybe Fanaticus developed but an ultra-sonic humidifier is introduced to keep humidity up. It requires very limited maintenance and works very well.

The first terrarium, the "Poor Man's Terrarium" requires no humidification. It relies on a very small volume of air and the fact the terrarium is sealed very tightly from the outside environment.

All of the last three of the terrarium setups require the same growing chamber. The difference is the strategy for keeping the humidity high inside of the growing chamber. If you want, you can start with one of the simpler versions and switch to a different setup later if you are unhappy with it. Note that if you start with the ultra-sonic humidifier version, we don't expect that you will want to switch to one of the other two.

Poor Man's Terrarium

Materials needed:

- 2 liter plastic coke bottle
- razor knife

This terrarium is made by cutting a section out of a 2 liter coke bottle. This serves two purposes. First, it allows you to put a fully colonized rice cake inside the bottle. The second purpose is it allows the volume of the bottle to be reduced to the point where the moistness of the rice cake can keep it humid.

Remove a section of the bottle using the razor knife. The cut on the lower part of the bottle is not very critical. The top cut is more difficult to do correctly. It needs to be right at the point where the bottle is starting to decrease in diameter. This is because the top part of the bottle is going to be inserted into the bottom part of the bottle and the two sections need to seal tightly.

The best thing to do is start lower than the diagram indicates and cut small sections off until the top piece of the bottle fits snugly and easily into the bottom section. Once you locate the correct place to cut for the type of bottle you are using, you can simply cut at the same place and make multiple bottles to handle as many cakes as you wish to fruit at any time.

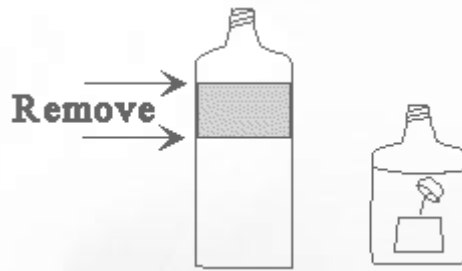

The cap for the bottle must be screwed on tightly. A damp paper towel can be placed on the bottom of the bottle to help raise the humidity inside the bottle. Twice a day the bottle should be opened to allow new air to be available for the rice cake to consume. It is best to fan the rice cake to insure new air is surrounding the cake before sealing it back in the bottle. This is the major draw back to this terrarium. If you have a dozen cakes it can become a burden to exchange the air twice a day.

Basic Growing Chamber (Used for all other terrarium setups)

Materials needed:

- Styrofoam Cooler [Adaptation-11](#)
- Wire Mesh (1/4 or 1/2 inch is ideal)
- Plexi Glass (a 24 by 24 inch piece of window insulation or fluorescent light diffuser) Optional if using an ultra sonic humidifier.
- Silicon Glue
- Humidity Gauge [Adaptation-12](#)

The cooler needs to have a very tight fitting cover. The idea is to seal in humidity, and the looser the lid is, the more difficult this is. Except for the cooler, everything you need can be found at your neighborhood building supply store. Below are diagrams detailing the various components of the terrarium. There is no way to predict the dimensions of the cooler that you will use. You will need to use some common sense as we walk you through the steps to build your terrarium.

Front View of Terrarium

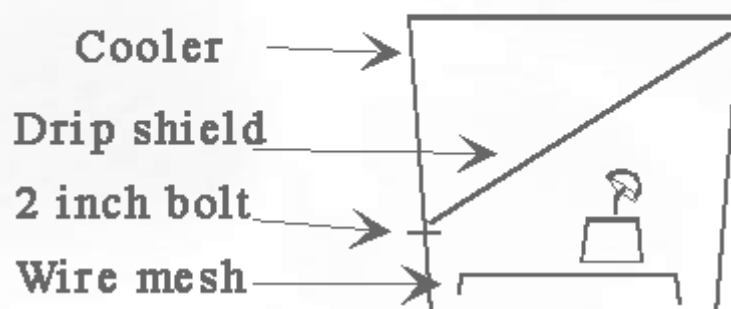

Front View of Terrarium

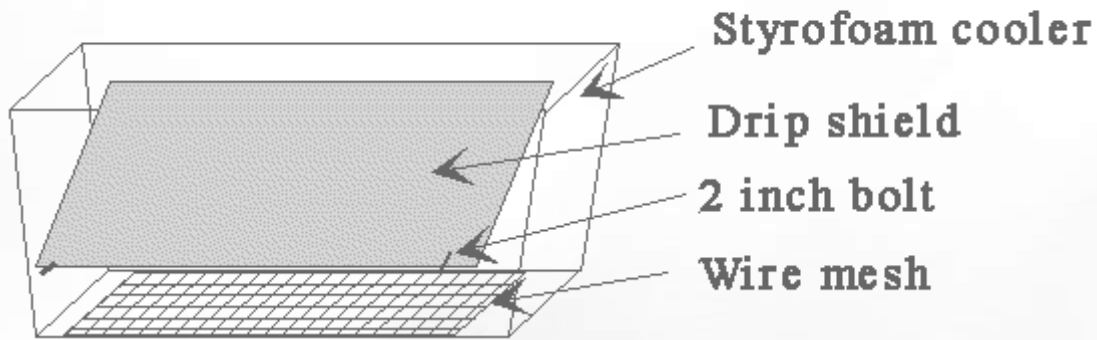

The purpose of the wire mesh is to hold the rice cakes off the bottom of the cooler where moisture will collect. The easiest thing to do is cut a piece of wire mesh an inch wider and an inch longer than the dimensions of the bottom of the cooler. Then, use a pair of pliers to bend a 1/2 inch ridge all the way around the piece of wire mesh. The piece of mesh will be held up by the bent ridge. Often times, when mushrooms are growing, space above them is at a premium. Try not to raise the wire mesh more than a 1/2 inch above the bottom of the cooler. Doing that simply wastes valuable space.

Next, if you are going to use the hand sprayer method of adding humidity, a drip shield needs to be installed. If you are using a fish tank bubbler or an ultra sonic humidifier, it is optional but still a good idea. As moisture condenses inside the terrarium, this protects the rice cakes from being 'rained' upon. Any moisture that forms on the lid of the cooler can drip and will be stopped by the drip shield from hitting the rice cakes. Any moisture that forms on the bottom side of the drip shield will form beads and run down to the side of the terrarium where it can drip harmlessly. If you use a piece of plexi-glass that is textured on one side, put the textured side pointing up. You want a smooth surface on the bottom side of the drip shield so that moisture can easily run down to the side of the terrarium.

The drip shield is held up by several bolts sticking through the side of the cooler. Depending on what size canning jars you use and the height of your wire mesh, you will need to figure out where to put them. You want the drip shield to be at as steep of angle as possible to make water run down it easily, but you want it high enough that your mushrooms have room to grow without touching the drip shield. The drip shield needs to fit well. You need a small gap on the edges to let air circulate, but keep it small. About 1/4 inch is good. In other words, the drip shield should fit pretty well to the inside of the cooler, but it is not supposed to be air tight. Also remember when shaping the drip shield that you can not go to the very top of the cooler because the lid will recess into the cooler a little ways.

If you are using a Styrofoam cooler, you should use washers on the bolts on both the inside and outside of the cooler. This will allow you to tighten the nuts on the bolts snugly to keep the bolts from tearing up the cooler as you move the drip shield during normal maintenance.

Next, the top of the cooler needs to be modified to allow light to enter the terrarium. *Psilocybe Cubensis* is a phototropic mushroom. It needs light to initiate pinning and to tell the mushrooms which way is up. You should have some plexi-glass left over from the drip shield that can be used for this purpose. Cut a hole in the top of cooler. Cut a piece of plexi-glass a little bit bigger than the hole in the cooler lid. Run a bead of silicon glue all the way around the hole in the cooler top. Position the plexi-glass over the hole and let the glue setup. See the following diagram:

Cooler Lid

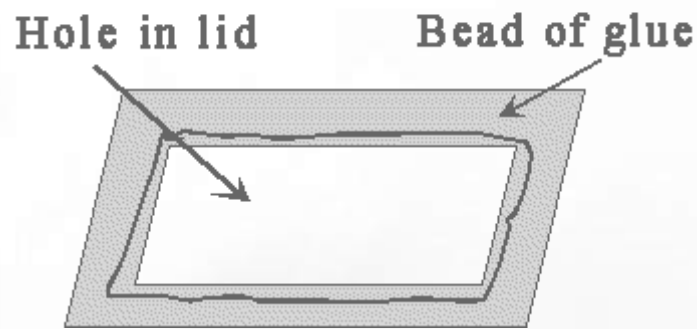

That is it. The basic grow chamber is done. Now you need to decide which method you are going to use to keep the humidity high and the CO2 concentration low while the mushrooms are growing.

Method 1: Hand Spraying

This is the original method that *Psylocybe Fanaticus* recommended for the home cultivator to grow mushrooms. It is the least expensive. It is the most labor intensive and forces you to conform to a demanding schedule. The only thing you need in addition to the basic growing chamber is a spray bottle that can put out a fine mist.

The procedure is this: At least four times a day the terrarium needs to have humidity injected into it via the spray bottle. At least twice a day the CO2 that has built up needs to be eliminated. Once a day you need to eliminate water from the bottom of the terrarium that has condensed and formed there.

Once a day, you need to remove the standing water from the bottom of the terrarium. You can use a turkey baster to suck the water out, or you can gently remove each cake and turn the terrarium up side down to drain the water out. If you remove the cakes, be very gentle. Any place you touch the cakes will not fruit. You should pick up the cakes in the same place every time.

Twice a day, the CO2 that has accumulated in the chamber needs to be removed. One method is to remove the drip shield and fan the inside of the cooler with the cover for 10 or 15 seconds. Another method that works well is to have a hair dryer next to the cooler and use it. Simply lower it into the terrarium with the exhaust jet pointing up and out of the terrarium and turn it on. It will suck all the existing CO2 out of the chamber. Be sure not to hit the rice cakes with the hot exhaust air. It will damage them. If your hair dryer has a 'cool' setting, use that instead of 'hot'. Incidentally, one cultivator recommends using a vacuum clean instead. He would simply suck the stale air out of the terrarium.

In order to create humidity in the terrarium a spray bottle that is capable of generating a fine mist is used. There are a lot of different products for use in the kitchen that have an adjustable spray nozzle, but if you choose to recycle one of these, make sure it produces a very fine mist. What ever you use, make sure it is entirely clean of the original chemicals. Let's make this perfectly clear. Make sure the bottle is clean and does not contain anything that will damage the fungus. The safest thing to do is go to the hardware store and buy a high quality spray bottle. These typically produce a finer mist than most kitchen type spray bottles. The problem is that you would not be using a spray bottle if you had a little extra cash so we are telling you that you can use a kitchen spray bottle if you are careful. In order to create the necessary humid environment in the terrarium, the nozzle is slipped under the cover of the cooler and sprayed at the center of the top side of the drip shield. See the following diagram:

Hand Spraying the Terrarium

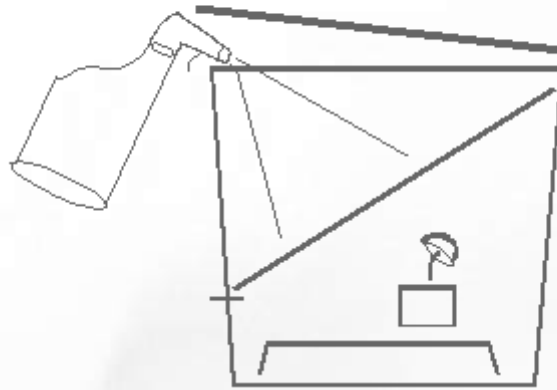

After spraying for 5 seconds, pull the spray nozzle out of the cooler and let the lid quickly close, sealing in the vapor. The small water drops will dramatically raise the humidity of the chamber. The rice cakes can not ever be sprayed directly. The mycelium is very fragile and doing that will damage it. The terrarium needs to be sprayed at least 4 times a day. More is better.

This setup and procedure will work and is very inexpensive, but that is the only good I have to say about it. You become a slave to your terrarium. If you miss a couple sessions, your fungus will most definitely suffer because of it. Also, you can only support a few growing mushrooms at a time using this procedure. The mushrooms pull a lot of humidity out of the air and this method doesn't provide much excess.

Method 2: Using a Fish Tank Bubbler

The basic portion of this system was originally pioneered by Psylocybe Fanaticus There are several improvements and adaptations in this section that were not included in the original method. The idea is to create humidity by bubbling air through water. A small fish tank air pump and bubbling stone are used to accomplish this.

This method is inexpensive and allows the terrarium to exist without your constant attention. Its major limitation is that depending on how it is implemented, it can only raise the humidity by 15% over ambient. The minimum acceptable amount of humidity needed by the fungus is 85%. If ambient humidity is going to be less than 70% during the growing cycle, you will experience problems even with a fully optimized setup. If you have more than a few mushrooms growing, it is possible this system will fail to keep the humidity high enough. You still need to hand spray the terrarium occasionally to boost the humidity above what the bubbler can do. Several times a day is sufficient.

All of the materials needed can be obtained at any pet store or pet department in a department store.

Materials needed:

- suitable container for water
- Fish Tank Bubbler
- 3 feet of 1/4 inch air line for fish tanks
- bubbler stone
- optional submersible 50 watt fish tank heater [Adaptation-13](#)
- optional Angel Hair or plastic steel wool [Adaptation-14](#)

The basic strategy is to place a container of water inside the terrarium and slowly bubble air through the water. A hole should be cut in the drip shield to allow the container to stick up through it. The top of the container should be above the drip shield to protect the fungus from water droplets that will get produced. There are several ways the system can be implemented. If the air pump is setup outside the terrarium with just an air line going into the terrarium, the humidity will be raised less than 10% over ambient. The one benefit to this setup is the fact that air is constantly being exchanged and the home cultivator does not need to eliminate CO₂ every day. A small hole can be put at the base of the terrarium to let CO₂ and water escape. The hole should be just big enough that water does not bead up and plug the hole. A 3/8 inch hole will accomplish this nicely. Note that a small, snug hole needs to be drilled in the side of the cooler to allow the air line to get inside the cooler. You can not just loop it over the side of the cooler and slam the lid on it. You will not get enough humidity if the lid does not fit tightly. See the following diagram:

Use of air pump to add humidity

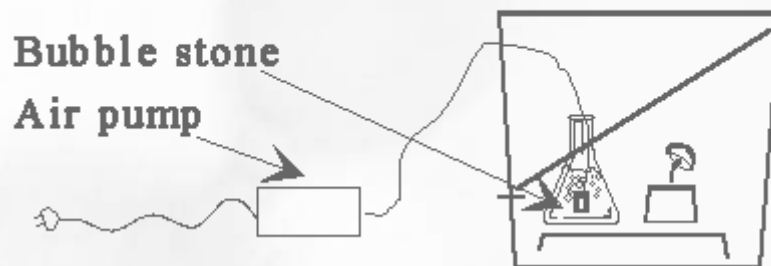

A second method to implement this strategy is to put the air pump inside the terrarium. This way the same air is constantly recirculated, constantly increasing its humidity. This can increase the humidity to close to 15% over ambient. This implementation has several disadvantages. First, the key to getting the higher humidity is recirculation of the same air over and over again. This means no hole can be placed at the bottom of the terrarium to allow water and CO₂ to escape. You will need to eliminate CO₂ at least once a day. The second disadvantage is the fact that the air pump generates some heat and can warm the terrarium by over 10 degrees F. This may or may not be acceptable. One point needs to be noted. The air pump will create some vibration. It is best to suspend the air pump from a rubber band to absorb this vibration. A stiff piece of coat hanger wire can be suspended from one side of the terrarium to the other and the air pump hung from it. Instead of the air tube going through the side of the terrarium, the power cord for the pump goes through the side. Also note that the positioning of the stiff wire to hold the air pump is not critical. It may be better to rotate it 90 degrees from what is shown in the following diagram so that it is easier to remove the drip shield when servicing the terrarium. Also, the power cord and air tube should have some slack in them so that are not being pulled on as the pump vibrates. The ideal scenario is to tie wrap them to the supporting wire. See the following diagram:

Use of air pump to add humidity

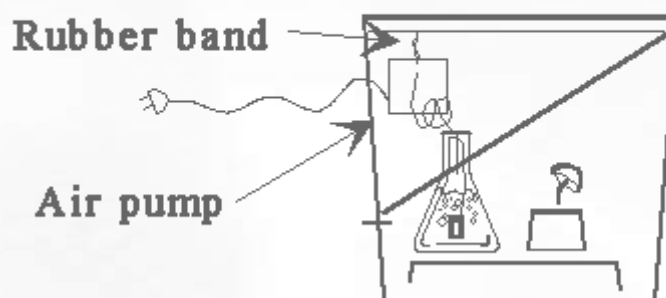

Method 3: Using an Ultra Sonic Humidifier

This is the best method. It will free you from the tyranny of your terrarium. It will effortlessly produce enough humidity to support as many mushrooms as you can grow at once. This setup will automatically eliminate CO2 buildup before it occurs. The only draw back is that ultra sonic humidifiers cost around \$40. A little more for a super nice one, a little less for a budget version. Just about any ultra sonic humidifier will work.

A steam humidifier is not easy to integrate into this terrarium setup. First, the vapor it emits is too hot and will kill the fungus. The second reason is they typically run full blast. They do not have a control to throttle them way back like the ultra sonic humidifiers do.

Materials needed:

- Ultra Sonic Humidifier [Where to find](#)
- 8 feet of 7/16 inch outer diameter, 5/16 inch inner diameter vinyl tube
- 1 dozen 3/8 inch inner diameter grommets
- 4 clear 2 liter coke bottles
- 3/8 inch, fine thread bolt
- tube of silicon glue
- pliers

First, a small hole needs to be placed in the Basic Growing Chamber to let water and CO2 escape. It should be at the very bottom of the cooler. It needs to be big enough that water will not bead up and plug it. 1/2 to 3/4 of an inch is good.

This setup uses the ultra sonic humidifier to produce air that is close to 100% in humidity. The air flow out of the humidifier is limited by the fact that it has to travel through the 7/16 inch vinyl tubing. That is OK, because we want to limit the amount of air we feed into the terrarium. The humidifier will generate very humid air, but the air will also have many suspended water particles in it. Any time one of these water particles touches another water drop, they will merge. We don't want moisture forming on the rice cakes, so limiting the number of suspended water drops we allow into the terrarium is a big step towards this goal.

Even so, the air must be dried further. [Adaptation-21](#) The air is passed through several stages where it is allowed to swirl and condense. Each one of these stages is comprised of an empty 2 liter coke bottle or some other suitable container. These stages are connected together using the 7/16 inch vinyl tubing.

Every time a piece of vinyl tubing is used, it needs to be fluted. This means it is not cut off square, but rather at a very sharp angle. This is necessary to help moisture that condenses inside the line to drip out once it reaches the end of the line. Otherwise, it will form a big drop and eventually plug up the line. At that point you have no humidity entering the terrarium.

Drill a 7/16 inch hole in the center of the exhaust lid for the humidifier. Insert a grommet. Apply a bead of silicon glue to the slit through which vapor normally exits. You want to plug this slit up. The only exit for vapor should be through a piece of vinyl tubing that will be placed inside this grommet.

Remove the labels on the coke bottles. Any large plastic container can be used but the 2 liter coke bottles are real nice because they allow you to see inside. [Adaptation-24](#) This is useful to determine if the terrarium is running correctly later. Also, you will be able to see if moisture that has collected in the bottle needs to be emptied out of it.

Heat up the threads on the 3/8 inch bolt using a propane torch or burner on a gas stove. A cigarette lighter will work, but it will take a long time. Hold onto the bolt with the pliers. When the bolt is hot, quickly and neatly poke two holes in each 2 liter coke bottle. [Adaptation-15](#) See the following diagram for details:

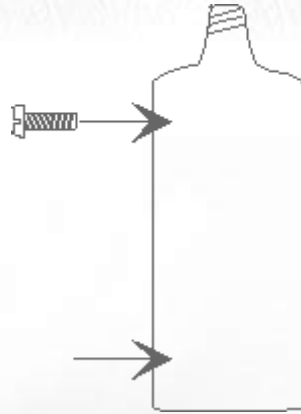

The bolt that is used is deliberately a little smaller than the hole that needs to be generated. The hot bolt will melt the hole a little bit bigger than it is when it pokes through the plastic bottle. You may need to insert the bolt a second time into the hole and let it touch the sides to expand the diameter of the hole. Some times little chunks of plastic stick to the side of the hole. Use a sharp knife to clean up the edges and insert a grommet. Check the fit of the vinyl tubing through the grommet. It should be very snug and air tight, but it should not collapse the inner diameter of the tubing very much.

Connect a piece of tubing from the humidifier to the first coke bottle. Flute both ends of each piece of vinyl tubing. Connect the this coke bottle to the next. Do this until you have all four coke bottles connected. The picture shows 3 coke bottles because that is what is normally required, but for now connect in all 4. Now connect the last coke bottle to the terrarium. You will need to poke a hole in the side and insert the tubing. The tubing should be blowing humid air into the part of the terrarium that is above the drip shield. It should be setup as follows:

Ultra Sonic Humidifier Setup

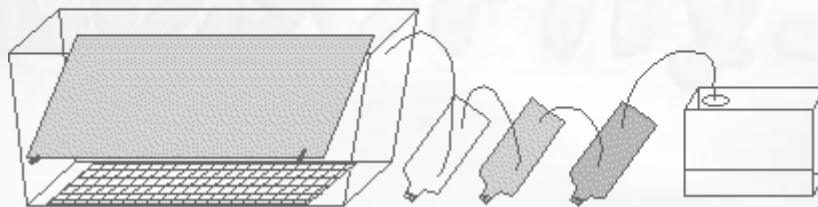

Checking out the Ultra Sonic Humidifier Setup

Fill the humidifier with water and position the various stages of the coke bottles between the humidifier and terrarium. At no place should the vinyl tubing have a low spot for condensation to form and plug up the line. Condensation will form in the lines but it should run to the end and drip harmlessly out of the line.

Set the humidity level at the minimum setting. This is still more than you should need. **Adaptation-19** After you give it time to stabilize, you should see that each stage of the coke bottles has less fog in it than the preceding stage. Usually, 3 bottles is the right amount, but depending on your humidifier and ambient humidity, it could be more or less. You want the last coke bottle to just have the slightest hint of fog in it. Add or delete stages as necessary.

The humidity in the terrarium should stabilize at about 90%. The ideal amount of humidity is as much as you can get without moisture forming on the rice cakes. Keep in mind that most humidity meters you get at department stores are not very accurate.

[Back to table of contents](#)

The Growing Cycle

This section is relatively short considering its topic. That is because when you get to this point you are only needed to make sure the fungus has the right conditions to thrive.

Once you place a fully colonized rice cake in the terrarium it just needs several things to grow mushrooms. It needs high humidity, temperatures below 85 degrees F. and a little light. Once the mycelium network has gained access to enough nutrients the cake can initiate mushrooms if conditions are right. The initiation of mushrooms requires some light and temperatures in the mid to upper 70's F. The mushrooms can grow at higher temperatures, and in fact grow faster at higher temperatures. But the fact remains that the temperature range is fairly narrow to start new mushrooms. Normally, it takes about a week for pin heads to form if the rice cake was removed from the culture jar as soon as it was 100% colonized. It can happen after just a couple days if the mycelium network is well established, or it can take several weeks if things aren't just perfect for the cake.

If you keep the terrarium's temperature in the mid to upper 70's F. you will be constantly initiating new mushrooms (pin heads) while providing a good environment for the growing mushrooms to mature. This is the simplest way to grow if you can arrange for this to be the case. [Adaptation-16](#) If you deviate outside of this temperature range, you will still get a few mushrooms, but the fungus will initiate new pin heads only occasionally. You will spend a lot of time waiting for a mushroom to form.

The rice cakes need a small amount of light to initiate pin heads. Mushrooms are not plants and do not need light to grow. However, *P. cubensis* is a phototropic mushroom. This means it needs light to trigger a hormonal response in order to form mushrooms. If you can see the rice cakes, there is enough light for this to happen. Many mycologists believe the reason light is important in the growing cycle is because it provides a reliable clue to the mycelium that it has reached the boundary of the substrate in which it is growing. In nature, *P. cubensis* often lives in a pile of cow manure. Once it has grown through the entire substrate and reaches the edge, light hits it and provides the mycelium with the information that if it forms a mushroom there, it can release spores into the air for distribution. It is not productive to form a mushroom inside the substrate because the spores can not be distributed in that case. Any normal spectrum of light that you have available will work. Sun light, fluorescent or incandescent are all fine and will work. A few minutes of light a day is sufficient but an hour or two will guarantee that pin heads form if everything else (temperature, humidity, the mycelium network is well established, etc.) is right. Be careful not to heat your terrarium too much if you use artificial light near the terrarium.

The rice cakes will have a very bright white appearance when they are first placed in the terrarium. Soon, they will be coated with a thin layer of fluffy mycelium. If the cakes refuse to fruit but continue to form more and more fluffy mycelium this is an indication that the humidity is too high and needs to be adjusted downward. For people using a humidifier in their terrarium setup, this is the single biggest cause of failure assuming they get the rice cakes colonized successfully.

When pin heads form, they will look like a short section of a common pin. Hence, the name. The end of these pin heads will soon grow dark brown. This is the cap beginning to form. When the rice cakes are fresh, the small mushrooms will start adding bulk rather than grow longer. They will form balls the size of a marble. Then, they will start to thin out and grow long, adding bulk the whole time.

If the mushrooms have mycelium growing on the caps, it is an indication that your humidity is too low in the terrarium. In this case, you have just enough humidity to allow the cakes to fruit, but you are right on the edge of failure.

You should avoid the temptation to grow the mushrooms as large as possible. Significantly more psilocybin is produced during the early periods of growth. By letting the mushroom grow too large you are simply consuming nutrients and moisture from the rice cake for no purpose. Also, the mushrooms taste increasingly bad as they get larger. Lastly, the mycelium network in the cake can only provide so much in the way of nutrients and water to maturing mushrooms. If you let the mushrooms grow too big, they will hurt the

development of other mushrooms on the cake. The mushrooms should be picked just as the veil underneath the cap is starting to tear away from the stalk.

On the average, you should expect to get between 4 and 6 average size mushrooms per 1/2 pint cake. On the average you should expect each cake to produce 1 mushroom a week but this number can vary in either direction greatly.

As the cakes get older, they will produce less and less and it will be more difficult for the mushrooms to grow. **Adaptation-17** This is a result of the moisture in the cake being consumed by the earlier mushrooms. You will eventually see mushrooms form and start to grow but never bulk up during the initial phase of development. These mushrooms will seldom get big enough to develop caps. You can harvest these mushrooms but it is an indication that the rice cake is about exhausted.

[Back to table of contents](#)

Drying and Preservation of the Mushrooms

Once you have grown and harvested some mushrooms, you need to think about preserving them. They will only keep for a short time in their fresh state. Sometimes a single mushroom needs to be harvested and it isn't enough for a dose. Other times, too many mushrooms will be fully grown for a single dose. Either way, you will be in a situation where you want to preserve them for later. And, even if this didn't happen, you may find yourself in a situation where you simply don't have the time or inclination to trip. The good news is that if they are dried correctly, nearly all of the psycho-active compounds can be preserved for many months.

There are several ways to dry them, but we will only cover the best way. What ever you do, don't use heat to dry them. Heat is very harmful to the psycho-active compounds. You will drastically reduce the mushroom's potency if you use heat to dry them.

Materials needed:

- 1/4 inch wire mesh
- old wash cloth or rag
- carton of Damp-Rid or Damp-be-Gone (Anhydrous calcium chloride)
- Medium or Large size Tupperware bowl with sealing lid

Several pounds of calcium chloride can be purchased for a couple of dollars at any large building supply outlet. It will usually be found in the paint department because it is used to dry the air in musty closets before painting and things like that. If possible, get the bulk refill containers. It will be cheaper than the calcium chloride that comes with the units to hold it and the moisture pulled from the air. You won't be using the unit, so don't buy it unless you have to.

The drying chamber needs to have a space at the bottom for water to collect. This allows the calcium chloride to function well for extended periods of time. As it pulls moisture from the air, it drips to the bottom of the chamber. The calcium chloride is held above the water by a circular section of the 1/4 inch wire mesh with a wash cloth spread out on it. See the following diagram for details. The wash cloth keeps the calcium chloride from falling through the wire mesh but any water that forms can drip through it to the bottom of the chamber.

Setup For Drying Mushrooms

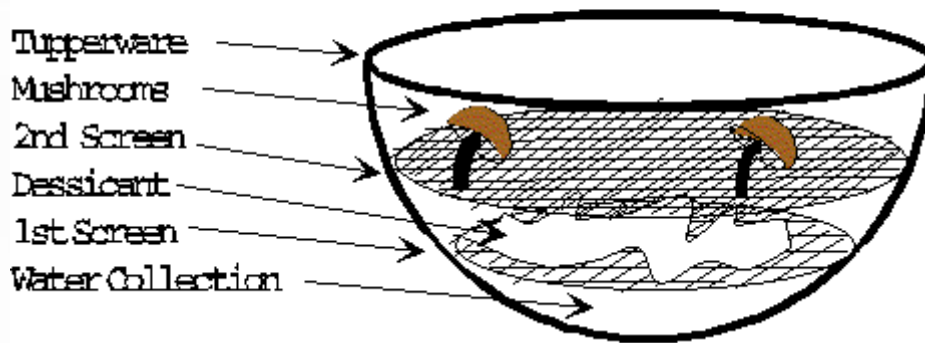

The calcium chloride should be spread out evenly. If you use too large of a Tupperware bowl, you may have to add some structural strength to the screen in order for it to support the calcium chloride. You can simply lay a stick or ruler underneath the mesh and use tie wraps to secure the mesh to it.

Cut another circular section of mesh so that it fits above the calcium chloride and leaves a nice air gap. The mushrooms will be placed on this mesh in order to dry them. Make sure the calcium chloride is not touching the bottom of this screen. There should be an air gap between the top of the desiccant and the bottom of the screen. You do not want your mushrooms to touch the calcium chloride while they are drying because some of it will dissolve into the mushroom if this happens.

That is the entire preparation for preserving your mushrooms with minimal loss of potency. In order to dry your mushrooms, simply harvest them and place them on the wire screen. Close the Tupperware container so it is air tight. The mushrooms will shrink and shrivel over the next couple of days. After about three days, they will be fairly hard and contain very little moisture. If you are not pushed for space inside the drying chamber, you may as well leave them there for five or six days to thoroughly dry them.

After the mushrooms have been in the drying chamber for three days, they can be moved to a zip-lock bag for long term storage. Remember that the dryer the mushrooms are, the longer they will keep. [Adaptation-18](#)

The reason this system works so well to dry the mushrooms is the calcium chloride is a good desiccant. It has a very strong affinity for moisture and can pull almost all the moisture out of the air. Eventually however, liquid will start to collect in the bottom of the drying chamber. Mushrooms are 92% water by weight. This moisture has to go somewhere when the mushrooms are dried, and it will eventually find its way to the bottom of the container.

When moisture starts to collect in the drying chamber you can simply drain it out and continue to use the old desiccant. The chamber will continue to work as long as there is sufficient calcium chloride in it. You should be careful not to contaminate the sides of the container or the top screen with residue from the desiccant. You do not want your mushrooms to touch the residue. For one thing, it tastes terrible, but in addition to this, the mushrooms will not dry completely. The residue will attract moisture. Whenever you empty the moisture, it is best to wash the Tupperware container completely.

[Back to table of contents](#)

Dosage and Various Ways to Ingest

First, we need to make sure some thing is understood. Before you dose, you need to be some one that likes your self and feels pretty secure about your self. You should not have any major troubles in your life. If this does not describe you, don't dose! Go find some other drug to play with.

OK, you've decided that your going to dose. After all, why did you grow these little devils if you weren't going to trip? The most important question to answer is how hard do you want to trip? If a 170 pound person had

never done alcohol before, this is the advise I would give him. Dosage could be anywhere from 1 beer to 12 beers. 1 beer is just enough that you might feel something, but everything will be pretty normal. 4 beers is enough you will have a strong sensation of what alcohol does, but you will be in complete control. At 6 beers, you will start to be drunk. At 12 beers, you are pig drunk and may pass out. I would recommend 4 beers the first time out. This would give you a good feeling for what alcohol is about, but still keep you out of trouble.

These mushrooms will be fairly consistent in potency. They are all grown on the same medium under the same circumstances. If you take 4 average *P. cubensis* mushrooms, that will put you at the same relative spot on the spectrum as 4 beers. But remember that psilocybin is more powerful than alcohol. What you experience will be more intense than 4 beers. However, on the spectrum of what is possible, you will still be on the low side. What are average size mushrooms? Mushrooms are like snowflakes. No two are the same. I would call a mushroom that has a stalk 3 inches long and a cap 1 inch in diameter average.

Drying the mushrooms as described in this document will have minimal impact on their potency. Many sources claim that dried mushrooms are significantly less potent than fresh ones. If you use the method to dry the mushrooms described in this document, you'll find that claim is not true. It's your choice whether to eat them fresh or in their dry state. Some people have strong feelings one way or the other because of their taste. Most people agree that these mushrooms will never win any culinary awards. Try some each way. Find out if one way or the other is better for you.

Some people find that these mushrooms cause some nausea. **AN165023@anon.penet.fi** suggests the use of digestive aids available over the counter at any pharmacy. This will make consumption of the mushrooms a lot easier on you if you are susceptible to nausea. Also note, that most people should avoid consumption of alcohol while using these mushrooms. When the mushrooms are mixed with alcohol, even people with cast iron stomachs can lose their lunch.

If you find the taste of these mushrooms particularly distasteful, you can always bury them in a burrito or peanut butter sandwich. If you do this, it will slow the onset of the effects some what. Some people just chew them up and wash them down with orange juice.

Some people dislike the taste so much, they are willing to go to extraordinary measures to disguise the taste. Several popular recipes follow. With the exception of the first recipe, these recipes all suffer from a common problem. They use heat. Heat will cause some of the psilocybin to break down and as a result you will need to use more mushrooms for the same effect than if you had ingested them directly. This fact in and of itself is not too big of a deal. After all, you can grow as many mushrooms as you need. A 25% to 50% loss of efficiency is not ideal, but it may be worth it to some people in order to avoid the nasty taste of these mushrooms. The real problem is it is impossible to predict how strong the effect is going to be. It depends on how hot you heat them when you do the preparation and how long they are hot. Use caution!

Mushroom Juice

Put several spoonfuls of frozen juice concentrate into a blender. Dole's Orange-Pineapple-Banana works especially well but regular Orange Juice or Lemon Aid will work. Add a bit of water, but keep the resulting juice on the strong side. Throw in a few ice cubes and your shrooms (fresh or dry) and whiz on high for a minute or so. Let it sit for a few minutes after you turn off the blender, then drink.

A 500 mg vitamin C capsule can be added and will make the juice more tart which is beneficial in masking the mushroom taste.

Mushroom Tea

Take the fresh mushrooms (6-7 per person depending on size of caps) and cut the caps and stems into very small pieces. Place mushroom pieces into medium sized pot 3/4 filled with water. Boil the water along with the mushrooms. Boil for ten minutes. Remove from the heat and let cool for 10 more minutes. Strain mushrooms with a coffee filter, or paper towel. At this point, if you truly desire tea, a mint flavored version works well. Otherwise, Kool-aid is an option. Grape Kool-aid mixed stronger than usual will definitely cover the taste. Serve with ice to chill the Kool-aid to the desired temperature.

Mushroom Soup

Using Ramen Pride or any other dried noodle soup, follow directions on package, except put cut and cleaned mushroom pieces in the broth. Prepare as usual. If the mushroom pieces are small they are relatively unnoticeable.

Mushroom Pizza

Cook your favorite frozen pizza according to directions. Several minutes before the pizza is done cooking, add finely sliced fresh mushroom pieces to the pizza. Optionally, you can add some grated cheese on top of the newly added mushroom pieces. Adding cheese will help encapsulate the mushroom pieces and dramatically help mask the taste. Place pizza back in oven and cook until done.

Obviously, some of the people that grow these mushrooms are going to be looking for a 'mind melting' experience. Bad trips on mushrooms are rare, but they do happen. One of the most common reasons for bad trips on mushrooms is taking a high dose of mushrooms that have grown on cakes that also have contamination growing. Toxins get absorbed by the mushrooms growing on these contaminated cakes and as the dosage gets higher it starts to become an issue. Care should always be taken to avoid contamination but if you plan to dose on the high side, it is absolutely mandatory. Think about it. How fun would it be to have a nasty allergic reaction to some toxin while tripping hard. The email I've received on the subject suggests it is not very pleasant. Throw out any cake that is contaminated and any mushrooms that were grown on that cake even prior to when the contamination was noticed.

One final note. If you ever find that you have dosed too heavily, just remember that 90 minutes after ingestion will be the peak experience. Things will start to settle down after that. The good news is that medically you can't overdose on psilocybin. If you remember these things, and believe them, they can help ease you through a high dose experience.

[Back to table of contents](#)

How to Get a Spore Syringe

This section is ordered for some one just starting off in the home cultivating experience. Once you have grown a crop, this section is ordered backwards for your needs. The intent is to get you started easily. In order to grow subsequent generations of fungus you need to generate a spore print and use this to create a spore syringe. This information is at the tail end of this section.

In order to use the process detailed in this document, you need a sterile, viable spore syringe. The spores should be *Psilocybe Cubensis* spores. Preferably, they should be of the Amazonian strain. The Amazonian strain has wider parameters for fruiting and is more tolerant of mistakes. However, any *Psilocybe Cubensis* strain will work. There are several ways to get started. The easiest way to get started is to order a spore syringe but alternatively, you could obtain a spore print and use that to prepare a spore syringe.

Once you have grown some mushrooms, it is worth while to learn how to generate your own spore prints so that you can produce spore syringes when ever you need one. Currently, you don't have to do this if you choose not to because the spores are still readily available from mail order suppliers. Many people believe the day is coming when this will not be true. Many of the sources of psilocybe spores have quit selling to the public and others have destroyed their cultures because of mandates given by the DEA. If you have a sterile, viable spore print, you can eliminate your dependence on these suppliers.

Sources for a Spore Syringe

(Check all sources for current address and prices before ordering)

[Note: The following information about Spore Syringes is very out of date. The listed businesses may no longer sell spores, prices may have changed, ownership/management may have changed. Psylocybe Fanaticus is no longer in business. Verify everything before acting on any of the information in this section.]

Currently the most cost effective place for a United States resident to order a spore syringe is from the company that pioneered many of the concepts in this document. They have a very fast turn around time and are very reliable. Their spore syringes are \$10.00 (US) and that includes shipping. They are very high quality. They currently supply P. cubensis Matias Romero. This is a substrain of the Amazonian strain.

If you are outside the United States, there is a \$10.00 shipping charge. All their packages are shipped in a discrete manner. However, be aware that outside the US, a customs sticker with the description "mushroom spores in blunt-tipped pipette" is stuck on the box.

If you wish to minimize the paper trail, you can send cash to Psylocybe Fanaticus. They are totally reliable and you will get what you order. Psylocybe Fanaticus advertises that they do not keep customer files and by sending cash, you can distance your self from any records of the transaction.

If you learned about Psylocybe Fanaticus here on the Web, please mention it when you order. Currently, Psylocybe Fanaticus doesn't believe much business comes their way because of the net. We would like for that to change.

In Europe, there is a very cost effective spore seller, [Smart Botanics](#). They also sell dried mushrooms if your country will allow them to be imported. They only charge \$8.00 for a spore syringe and \$3.00 for shipping. You can place an order through the mail or directly from their web page.

Also of interest is the fact that this supplier can provide you with either the standard strain of Psilocybe cubensis spores or 'Gulf Stream' Psilocybe cubensis spores. The 'Gulf Stream' strain is slightly more tolerant of heat and fruits a little easier in warmer temperatures. The standard strain is more appropriate for cooler climates. Simply specify which one you prefer when you place your order.

Check, Diners Card and American Express are accepted.

Smart Botanics
P.O. Box 158, 2800 AD Gouda
The Netherlands.

In Canada there is a company called Hemp Nation. They are reliable and ship promptly. They sell suitable [spore syringes](#) (Psilocybe Cubensis Amazonian strain) for \$20 (US). There is a \$5.00 shipping charge within North America. I used to say the main reason you would want to order from this company is they are in Canada. If you're in Canada, your order will not have to go through customs. There is another reason you might want to order from this supplier. This company is the focus of a Constitutional Challenge to legalize hemp in Canada. The profits from your purchase will assist this.

Christopher Clay, Proprietor
Hemp Nation Headquarters
343 Richmond St.
Suite #101
London, Ontario Canada N6A 3C2
Phone: (519) 433-5267
Fax 433-7725
E-mail: hemp@hempnation.com
<http://pobox.com/~hemp>

Also in Canada, there is a company called Hemp-BC. They are reliable and ship promptly. They sell suitable spore syringes for \$30 Canadian. U.S. currency is accepted. There is a \$5.00 shipping charge within North America. If you're in Canada, your order will not have to go through customs.

Hemp BC
324 West Hastings, Vancouver BC
ph (604) 681-4620
fax (604) 681-4604

On the net they have a site: WWW.HEMPBC.COM

Sources for Spore Prints

In the event you wish to start with a spore print instead of a spore syringe, this section provides a few places you can obtain suitable spore prints. In general, the first time grower really ought to start with a spore syringe because it eliminates many of the sterility issues. The one benefit to starting with a spore print is you can make close to fifty 10 cc. spore syringes from a single spore print. However, this is really a moot point. Once you have grown a crop of mushrooms, you can generate as many spore prints as you want. One spore syringe is guaranteed to produce a crop if you follow the directions in this guide.

Mostly, this section is included just for completeness. In the event you can not obtain a spore syringe for some reason, you can get a spore print and use that to make a spore syringe.

The following information was pilfered from the mushroom FAQ on Hyper-Real.

Homestead Books P.O. Box 31608 Seattle, WA 98103 Pacific Exotic Spora P.O. box 11611 Honolulu, HI 96828 The Shroom King P.O. Box 17444 Seattle, WA 98107 SYZYG P.O. Box 619 Honaunau, HI 96726 J.L.F. P.O. Box 184-SC Elizabethtown, IN 47232	P. cubensis spores (\$25), kits (\$70), and books/videos about growing. (Phone: +1-206-782-4532) Panaeolus cyanescens and Coplandia cyanescens spores. Very expensive, \$40-\$75. Str. cubensis print and a book for \$25, above above plus compost and agar for \$35. (Phone: +1-206-784-9328) \$15 + \$1 (S&H) for a Str. cubensis print on a slide. Supposedly sells some rare species ready to and lotsa weird stuff. Free catalog. (Phone: +1-812-379-2508)
-----------------------------------------------------------------------------------------------------------------------------------------------------------------------------------------------------------------------------------------------------------------------------------------	-----------------------------------------------------------------------------------------------------------------------------------------------------------------------------------------------------------------------------------------------------------------------------------------------------------------------------------------------------------------------------------------------------------------------------------------------------------------------------------------------

How to Make a Spore Syringe

Sterility is key. If your spore print is contaminated or you introduce contamination into the spore syringe, you will have difficulty later in the process. Ideally, there should be no fans blowing or drafts of air. You should clean the area where you will be working carefully and make sure that everything is tidy.

Materials needed:

- spore print
- 10 cc. syringe with long needle [Where to find](#)
- shot glass
- regular glass
- coffee mug
- cigarette lighter
- X-Acto knife or sharp steak knife
- microwave oven

Several things need to be accomplished. First, we need to sterilize a shot glass to easily mix the spore solution and we need to sterilize a syringe to hold the solution. We also need some sterile water in which to suspend the spores. The following procedure will accomplish all of this.

Fill a coffee mug with water and place a shot glass inside the coffee mug. Make sure the shot glass is completely submerged. Place the coffee mug in the microwave oven and get the water to a full boil for 10 minutes. It does not need to be a violent boil. Adjust the heat level of the microwave oven to keep too much water from being lost if necessary.

Remove the shot glass and empty the excess water out of the shot glass. Place another glass over the shot glass. This will keep air born contaminants from settling in the shot glass while you wait for the shot glass and water in the spore syringe to cool.

Fill the syringe with hot water from the mug. Eject the hot water and repeat several times. This will insure the inside of the syringe and the needle are clean and sterile. This is especially important if you are using a syringe from a previous crop. When the needle is inserted into the substrate, it is possible to get nutrients up inside the needle and for contamination to grow. The last time you fill the syringe with hot water, do not purge it. Let it sit in the syringe until it is cool. This is useful for two reasons. First, the continued heat from the water can still work to eliminate any remaining contaminants. Secondly, once the water is cool it can be used as the sterile water needed to fill the syringe. Make certain that nothing touches the needle of the syringe.

The Psilocybe mushroom spores will be killed if they come in contact with anything too hot. You need to wait until the shot glass and spore syringe are at room temperature. When it is safe to proceed, use the cigarette lighter to flame sterilize the X-Acto knife and the needle of the syringe. Let the blade of the knife cool, but make sure it does not touch anything. When it is cool, carefully open the spore print and scrape a fleck of spores into the shot glass. A fleck 1/4 inch by 1/4 inch is more than sufficient for a 10 cc. spore syringe. Use the needle of the syringe to stir the spores into a few drops of water. Usually, there will be a few drops left over in the shot glass from when you emptied it. Otherwise, you can get the drops from the syringe. Stir the fleck of spores until they are well broken up and 'dissolved' into the water. Purge the water out of the syringe into the shot glass. Pull the water back into the syringe, being sure to suck the spores in also. Do this once or twice more to make sure the spores are well mixed in the spore syringe. Often, it takes several tries to get the spores fully broken apart and well mixed.

If the spores in the print have been dried and are not fresh, it is best to wait six hours to use the spore syringe. The spores need to rehydrate. If your in a hurry, the spores can still rehydrate in the culture jars.

How to Make a Spore Print

Once you have a mature mushroom, you are in a position to make a spore print and use it to continue cultivation of mushrooms. The cap should be harvested when the mushroom cap has become flat or is starting to invert.

Sterility is key. [Adaptation-25](#) Be careful not to do anything that will compromise the sterility of your spore print. The typical procedure is to cut the stalk off of a mature mushroom very close to the cap. A sterilized

knife or razor blade is used to do this. The cap is then laid on a sterile piece of tissue paper or card stock and a small glass set over it. The glass is needed for two reasons. First, it keeps the spore print insulated from airborne contaminants. Secondly, it helps keep the humidity high so the mushroom cap can continue to live and drop its spores. One note of caution. Some humidity usually needs to be allowed to escape. You want the environment inside the glass to be slightly less humid than the environment in which the mushroom was grown. If you have problems getting a cap to drop its spores, try using a piece of paper for the print that fits entirely inside the glass and spreading out a wash cloth flat on the table. Let the edge of the glass seal to the wash cloth instead of the paper. This will usually allow enough humidity to escape to cause the cap to drop spores.

If everything goes well, after a day or two the cap will drop its spores. [Adaptation-26](#) There will be a purple-brown dust underneath the cap. These are the spores.



Eye glass lens paper is good source of sterile tissue paper. A box of waxy tissue paper that deli's use to pick up donuts and rolls is another excellent source of sterile tissue paper. Card stock (such as a recipe card) is a bit easier to use later when you want to prepare a spore syringe, but you have to expend the extra effort up front to sterilize it. To use card stock, place in a 425 degree F. oven for 15 minutes. Let it cool with a glass over it before you place the cap on it.

Once you have a spore print on the paper, remove the glass and cap. Fold the spore print in half and seal the edges so air can not get in. A piece of scotch tape on each side will do nicely. The spores will stay viable for 18 months if they are kept in a cool, dry and dark spot. If you place a small amount of desiccant in the bottom of a film container and place a cotton ball on top of the desiccant, you have an ideal container to keep the spore print. The cotton ball will keep the desiccant from touching the spore print. Seal the spore print in the canister and place the canister in your refrigerator until you are ready to use it.

Note that if you want to be self sufficient, it is a good idea to have multiple spore prints and store them separately. You just never know when you are going to be surprised with a massive contamination problem or thermal death. The safest thing to do is have a couple viable spore prints so it is easier to recover from disaster. A spore print is typically viable for about a year if it is stored in a cool, dark location. As a print ages, germination gets slower and this process becomes more prone to contamination.

Combination of Spore Print and Preparation of Inoculant

This excellent idea is from: AN165023@anon.penet.fi

If it is your intent to use a mushroom to immediately generate inoculant for a successive crop, you can eliminate some of the above steps and reduce the risk of contamination.

Poke a small nail hole in the cap of a wide mouth jar. Cover the nail hole with a piece of electrical tape. A 1/2 pint canning jar similar to that used for the cultures is fine. Sterilize both the jar and the lid.

Place the harvested cap in the sterilized, wide mouth jar. Seal the top with the lid and wait until a spore print has been generated on the bottom of the glass. Open the jar and remove the mushroom cap. Add 3/4 cup of

sterilized water. Seal the top of the jar with the lid and shake the jar. The spores need to be mixed well into the water. This procedure eliminates the need to transfer spores from a print to some container to make the solution. The spore print is generated inside the container and the only extra step is adding water. It also has the benefit of making a large amount of solution that is easy to use.

Now, any time you need inoculant, you can shake the jar and peel the tape back to expose the nail hole in the lid. Simply insert the needle of the syringe into the inoculant and pull some into the syringe. The syringe needs to be sterile or you risk contaminating the entire jar of solution. The solution will keep longer if you refrigerate it. You still should keep some spore prints on paper because it is possible to contaminate the entire jar of inoculant if you make a mistake.

[Back to table of contents](#)

The Author's First Trip

OK, some of you experienced druggies are going to get a chuckle from this. This is a description of my first trip. I grew up in a real conservative environment. I always wanted to hallucinate but I was real scared of LSD. After all, I'd been told it causes chromosome damage and that a lot of the people that trip on it either jump out of windows or end up in a permanent psychosis. I'd heard that even the lucky ones that make it through the trip ok suffer from uncontrollable flash backs for the rest of their life. Pretty scary stuff.

I never was around people that used psychedelics much. The few times I had the opportunity, I was unable to find out enough about the source and quality to put my ignorant self at ease. It seemed like I was never going to get to have a psychedelic experience.

Well, I was surfing the net one day and decided to test the reach of information contained on it. I was trying one exotic topic after another in Yahoo. I was amazed at the knowledge contained on the net. I decided to push it to the limit. I asked about psilocybin. To my amazement, a few indexes to documents came back. I quickly downloaded them and started studying them. I was astonished to find out that the spores for Psilocybe mushrooms could be mail ordered because the spores did not contain any controlled substances. And best of all, there was no overdose for psilocybin.

It doesn't take a rocket scientist to figure out what I was thinking! The net contained bits and pieces of information. I was able to learn some of the basic concepts for growing shrooms but there was a lot of uncertainty and contradictions in the information I had. I kept increasing the depths of my searches on the topics. It eventually became obvious that my best chance of success lay with Psylocybe Fanaticus' method. I promptly ordered their Tek Notes and a spore syringe.

I followed their directions and had cultures well under way soon enough. But, I was frustrated with their humidification techniques. They did not work for me even though I experimented like crazy. My job involves doing research and development at a high technology computer company. I was determined to solve the problem and make it easy for others with access to the net to succeed. I found a few people on the alt.drugs news group that had vast mushroom growing experience and they helped me with advice that got me over some of my initial problems.

I was going home in a few months on vacation to visit old buddies. I told them I thought I was going to be able to bring some shrooms so we could all trip together. They freaked with joy. I have a basic personality flaw. Anything worth doing, is worth doing to excess. I didn't know how many shrooms I would need so I figured I had better grow a couple pounds. I worked out the problems I was having and simultaneously ramped production. I had a couple pounds of dried mushrooms by the time I headed north on vacation.

We were at a friends cabin on the lake when the time was right. I broke out my stash of shrooms as we prepared to go out on the lake fishing. Of course I offered some advice about what I thought was a reasonable first dose, but then I made the mistake of trying to comfort them with the information that it was impossible to overdose on psilocybe mushrooms. My friends have my same basic personality flaw about doing things to excess as I do, except worse. The closest I can figure, I ate about an eighth of a cup of crushed, dried shrooms and they all ate about twice that. **My first dose was significantly higher than the Dosage section of this document recommends. Just because I got away with it, doesn't make it a smart thing to do!**

Being the scientific type, I grabbed my camcorder just in case we needed to document anything and we headed to the boat to go fishing. The first 25 minutes seemed pretty normal, but then I started to feel myself coming on. I had done enough research to know that the peak experience was a good hour away. I kept fishing. Soon I had to put down my fishing pole and just watch my buddies. I just had way too much stuff going on to be holding my fishing pole.

I had heard that the most basic visual experience was how colors became vibrant while tripping. I kept looking for this, but never noticed it. I was wondering if we dosed high enough or if I had gone to all the trouble to grow these damn things and eat those awful tasting shrooms for nothing. I started to feel a little down. I just stared at the seat where one of my buddies was sitting.

Suddenly the seat was alive. I became mesmerized by how the grain in the wood seats of the boat would not stay still. Every time I looked at the seat, it would ebb and flow. Too cool! The surface of the water was even more intense. The patterns formed by the little ripples and waves were unbelievable. I was frying big time. Even though my buddies dosed way higher than me, they seemed unaffected. They just kept fishing and cracking jokes. I was still 30 minutes from peak.

I was looking across the lake at the far shore. There were lots of clouds blowing across the sky. I was enjoying just watching them. Then it happened. It became obvious to me which clouds were going to break apart into little clouds and which little clouds were going to combine to make bigger clouds. I spent a lot of time trying to figure out if I was just imagining this ability or if I could really do it. I just kept watching the far shore. Eventually my buddies noticed my fascination with the far shore and I became the focus of their jokes. They still didn't seem like they were tripping. I told them about my new found ability. That only encouraged them to make more jokes. I challenged them to predict which clouds were going to break apart and which ones would combine. They admitted that would be impossible. When I told them I thought I could do it, the jokes really started.

Naturally, I had to prove I wasn't making up this ability. I started pointing and telling my buddies which clouds were going to do what. They were real skeptical at first, but finally I convinced them. One of them realized that we ought to get this on the camcorder tape or nobody would believe this had happened. It was a little work to get the camcorder setup because we were so fucked up, but I got about 5 minutes of this on tape. This was real valuable in making me a believer that psychedelics really can expand your mind and give you insight that you never had before.

Later that day, everybody commented on how they thought they were the only one affected by the shrooms until the cloud incident happened. We were all having a good time, but nobody recognized that the others were tripping hard. I was only at 1/2 the dose my buddies were at, so it's not too hard for me to believe they were really looped.

The next day, everybody wanted to trip again. I gave them some advice. I told them that a person's tolerance builds quickly to psilocybin and that they would have to dose significantly higher to get the same effect. Interestingly enough, they all thought they wanted a little less of an experience. The first trip had tired everybody emotionally and intellectually. Strangely enough, that day, straight or tripping, I was unable to repeat my cloud predictions. It seems to have been a one time experience. Yet, I know and have proof I was able to do it that one time. It turns out the real life value of being able to predict cloud behavior is pretty small, but the important point is that psychedelics can give you insight you would not have had otherwise.

When we got back to town, all my buddies wanted me to teach them how to grow shrooms. My buddies are not

very scientifically minded people. I have been trying to get them to use computers and get on the net for a long time with no success. I did not think I could just explain the steps and have much probability of them succeeding. I thought about this problem for a little while. I wanted to write a comprehensive guide for the people on the net and I wanted to get my buddies on the net. I could kill two birds with one stone. I told them that if they figured out how to get on the net, I would have a simple guide there for them to follow.

[Back to table of contents](#)

Bulk Substrate Growing

This section is for the mycophile that has some experience and desires to cultivate a large crop of mushrooms. This section is intended for someone that has already grown several crops using the PF Tek procedure detailed earlier in this document. This section assumes a certain amount of experience and expertise. Please do not attempt this technique without first gaining the experience; you will most likely fail if you do so.

The procedure detailed earlier in this document is the best one known for making it possible for a first time cultivator to succeed. But it is very inefficient and the culture jars take a significant amount of time to manufacture and colonize. If you desire to grow a large quantity of mushrooms, you will find it is not practical for your needs.

The following procedure is an adaptation of the traditional mushroom cultivation techniques. It assumes you have some experience and don't need to be warned about this and that. The following description of the bulk growing procedure should be sufficient for an educated person to follow. There are many fine books on the subject and rather than compete with them, I suggest you get one if you start having difficulties [The Mushroom Cultivator](#) However, if you are careful, these directions should get you a truck load of shrooms.

There has been such a demand for instructions to accomplish growing on a bulk substrate, the author has decided to help. But the following process has not been 'idiot proofed' yet. You will need to use common sense and adapt as issues arise. Please note that this process depends on sterile procedures being in place. If you fail, it will most likely be because you introduced contaminants.

Materials needed:

- 1 quart canning jars
- Whole Grain Rye (Organically Grown)
- Fresh Psilocybe Cubensis Mushroom or 100% colonized culture jar
- Pressure Cooker
- Food Processor
- 1 Quart canning jars
- Coarse Ground Vermiculite
- Large Cake or Roasting Pans
- Mixing bowl

Step 1:

The first step in the process is to generate several spawn jars. Place 2/3 cup of Rye in each canning jar. Add 3/4 cup of water to each jar. Loosely screw on the caps and sterilize the jars in the pressure cooker. 45 minutes at 15 PSI is usually good. Note that a pressure cooker is necessary for several reasons. First, bulk grain is more difficult to sterilize. Secondly, in order to get the grain to absorb as much water as possible, pressure is required.

As the Rye cooks, it will expand and all of the water should soak into the rye. Let the jars cool to room temperature. The rye should be loose and break apart if you rotate the jars. That is the main reason rye is used instead of some other grain. This will be important later.

Step 2

At this point you need mycelium to inoculate the grain. You will need a clean food processor and set of blades for it. If you can sterilize it in the pressure cooker, this is best. If not, throw it in the dish washer with lots of soap. Don't open the pressure cooker or dish washer until you are ready to use it.

If you are using a mushroom, perform the following steps. Sterilize 1/4 cup of water. Let it cool. Put the water and the mushroom into the food processor and turn the mixture into a slurry. Don't mix the slurry more than you need to. You are creating small fragments of mycelium by chopping up the mushroom. The more you chop it up, the more damage you do to the small pieces of mycelium.

Open each spawn jar and place 4 or 5 cc's of the prepared slurry in the jar. Close the lid and rotate the jar so the Rye kernels tumble and mix inside the jar. The idea is to get as many kernels as possible to have mycelium fragments on them. Loosen the lid and place the jars in a warm, dark location.

There are several reasons why tissue from a mushroom is preferred to spores for the inoculation of the spawn jars.

- Mycelium does not need to germinate. It starts growing immediately.
- Normally only 1/3 of the diakratic tissue in a multi-spore inoculation is capable of fruiting. By definition, this tissue came from a fruit body and is capable of fruiting.
- Since every mushroom grown on the bulk substrate is of identical genetic origin, they will be very close in potency.

If you are using a 100% colonized culture jar, perform the following steps. First, the culture jar should have been 100% colonized for at least a week. This lets the mycelium grow into the cake and results in more of it being available for the inoculation. Birth the cake, and place it in the food processor. Turn it into little pieces smaller than a pea. Dump the sterilized rye into the food processor and turn it on just long enough to mix things up well. Place the contents of the food processor back into the jar and cover it loosely.

The cleaner your environment the more likely you will get through this stage without introducing contaminants. This is the most likely place to induce failure.

Step 3

Loosen the lid and place the jars in a warm, dark location. In 3 or 4 days you should see isolated spots with white mycelium growing. Check the spawn jars periodically. When you see large areas of aggressive growth, tumble the Rye to mix things up. Rotate the jar enough to thoroughly mix the kernels. The idea of mixing the Rye is to get kernels with mycelium growing on them scattered throughout the jar. Ideally, no kernel should be too far from a kernel with mycelium growing on it. Repeat this process every 3 or 4 days when the mycelium growth has been aggressive for a while. Once there is mycelium growing within 1/2 inch of every other location no further mixing is needed. At this point just let the mycelium expand outwards until it is every where.

Step 4

Once every kernel has mycelium growing on it, leave the jar sit undisturbed for a week. The idea is to let the mycelium grow as fast as possible.

Step 5

Sterilize more jars filled with rye and water. Let the jars cool.

Step 6

Most food processors have a plastic blade that comes with them for the purpose of mixing things instead of cutting things. Use this if possible. Make sure your food processor and blade are clean. Empty the contents of a colonized spawn jar into the food processor. Turn it on until the Rye kernels are all broken apart. Add some of the freshly cooked Rye to the food processor. Depending upon your confidence and the sterility of your environment you can add anywhere from 4 to 20 times the amount of grain in your spawn jar. The less you add, the less likely you will have problems with contamination. The more you add, the faster you can create substrate. Initially, you should stay on the low side. Turn on the food processor and mix the freshly cooked Rye with the colonized Rye from the spawn jar.

Place this material in a container that can be loosely covered. This material should be treated exactly as the earlier spawn jars were treated except you should see quicker growth of the mycelium patches. The amount of

spawn you have can be compounded again and again until you have enough to inoculate massive substrates.

Step 7

Once you have sufficient spawn colonized and available for your substrate, lay it out in a deep cake pan to a depth of 1.5 inches. Attempt to keep the surface even. If you have a very clean environment, you can perform a mass expansion and lay out the uncolonized grain instead of waiting for it to colonize in the jar. This will save several days and a little effort, but in general it is not worth the risk.

Cover the pan with a sheet of plastic wrap. Do not seal it absolutely tight, but make sure that very little air is exchanged. Note that some air does need to be exchanged to keep the CO₂ level from getting too high. But air exchange increases the likelihood of contamination. Keep it to a minimum.

This is one of the big benefits to bulk substrate growing. Whatever grain is not used to prepare a substrate can be used as spawn for new jars. When you get to this point in the process, you can easily be preparing a new bulk substrate every couple of days. You just make sure you never use all of the colonized grain as substrate. You hold back some to use as spawn for the next set of jars.

Step 8

Wait a few days until the freshly laid out substrate is showing aggressive growth. Laying out the grain breaks up the mycelium networks, and it takes several days for the mycelium to recover.

Step 9

Casing the substrate is the next step. Various recipes are available but the simplest one consists of course ground vermiculite and water. Course ground vermiculite is a requirement because the fine ground vermiculite packs too tightly and seals the substrate.

Soak the vermiculite in water. Wring it out, but leave it fairly damp. Later versions of this guide will have exact measurements but for the moment, you will need to adapt. If any of you think you have an optimum mixture, please post it in the alt.drugs.psychedlics and rec.drugs.psychedlic newsgroups.

Lay out the casing material to a depth of 3/4 of an inch. Try to keep it smooth because this will result in the mycelium poking through everywhere at the same time. Cover with plastic wrap and wait. Typically, it will be about a week for the mycelium to break through the surface of the casing.

Step 10

Initiate fruiting. Take the plastic off of the pan and place it in your terrarium. Make sure you have the temperature at about 75 F. Have some indirect light available. As pins start to develop, use a hand sprayer to mist the casing and keep it moist. But be careful. Do not saturate it to the point of being wet and having water drops that will not soak into the vermiculite.

Step 11

After the first flush, you can get a smaller second and third flush if you let the substrate rest for a while. There are a lot of factors affecting this. One particularly important factor is how much of the first flush's moisture came from the substrate and how much came from the casing. If you can mist your casing several times a day, that will help the longevity of your substrate.

[Back to table of contents](#)

Where to find Difficult Items

Several items used by this guide can be difficult to locate. Currently, this section will be most useful by people in the United States, but input from others in order to expand this section will be appreciated.

Brown Rice Flour

If you can't find brown rice flour at a health food store near you, you can get some help from Arrowhead Mills. Their phone number is 1-800-749-0730. They used to sell brown rice flour as a mail order item. They no longer do this, but you can ask them for the name and location of a store in your area that sells their brown rice flour.

It is one of their major products.

Ultra Sonic Humidifiers

Some ultra sonic humidifiers don't advertise the fact that they use ultra sonics in order to create humidity. For example, the 'Visible Mist' humidifier by Holmes is an ultra-sonic humidifier. If you can't find an ultra sonic humidifier at a department store or pharmacy, try calling Holmes. They make very good ultra sonic humidifiers. Ask for a distributor or retailer near you. Their phone number is 1-800-546-5637. Alternatively, you can break out your credit card and order one directly from them but the price is a little high (\$69.00) that way.

If you can not find an ultra sonic humidifier, you can use other humidifiers. Don't get too hung up with this item. The big problem to watch out for is heat. If you get forced to use a humidifier that is not ultra sonic make sure it does not put out a warm mist of air. Any ultra sonic humidifier can be made to work. This statement is not true of other humidifiers.

Vermiculite

Vermiculite is cheap and readily available. Vermiculite is made from ground up mica. It is normally used as an additive to potting soil to make the soil hold moisture and allow roots to easily penetrate through the soil. The easiest place to get it is a well stocked Garden Center at a local department store. If they sell several different kinds of potting soil and fertilizer, they will probably sell vermiculite. If they don't, be a little persistent and get some one that knows what the stuff is and ask where you can get it.

Prices vary dramatically, but a big bag of it with several cubic feet of vermiculite usually runs less than \$10.00. Much smaller bags are available and sell for several dollars.

If you can't find vermiculite in any of the well stocked garden centers in your area, you can call Piedmont Pacific. They are a large supplier of vermiculite. Their phone number is 1-770-725-6853. You can ask them for the name of a store in your area that sells vermiculite.

10 cc. Syringes

The most likely place to find large syringes is a feed store. Some localities have ordinances prohibiting the sale or possession of syringes without a prescription. If this is the case, your simply going to have to order a spore syringe and be careful not to damage it. Usually, a 10 or 12 cc. syringe can be purchased at a feed store for under \$1.00. If you don't have any luck at the feed store, you can try a local pharmacy. They usually have syringes, its just a question of convincing them to sell you a suitable one.

[Back to preparing the substrate](#)

[Back to Terrarium Construction](#)

[Back to table of contents](#)

Providing Feed Back and Getting Questions Answered

Growing mushrooms is not trivial. The proceedure used in this document drastically simplifies the process, but even so, you may find yourself in a situation where you need help. There are a lot of people that know about growing mushrooms in the alt.drugs.psychedelics and rec.drugs.psychedelc newsgroups. If you need help, you can almost always get solid advice there.

If you have a suggestion, you can get it to the author of this document by posting it to these same newsgroups. If you have something you only want the author of this document to read, please encrypt it with PGP and post

it to the above newsgroups. I will see it. My PGP key is:

```

Type Bits/KeyID      Date      User ID
pub 2047/B9182FE9 1996/08/24 MMGG Author
-----BEGIN PGP PUBLIC KEY BLOCK-----
Version: 2.6.3i
mQENAzIfd0cAAAEH/14DazcVKv1eRlNgt48GHgDurYxoyfB/5W7eNITF/6mCxa1I
0462zDjshitLqEQDYkg0FgYEs7rRpVJzs4JIc3swizy+e1c+d0xyB4ALswzJvMv
u50Vw+ddAT6+Qqcqo5 lbiFoGmTYWoK8BVtmc0ifzDk7GGmX3Yj4wic+/G1eslIew
dcBgcAZF9bQRtI36EgMLAktpb6gnC0tc2MyNxdY/BlRZ4bMsmqc/lgJumWZQkJyj
bamWs0nueRaFyQj0LWrN6okHP0FZaw3wUgsre/oqa2hSvKxTNjKtMocVVG7Ekut0
+hAkGfPoSmwrjnHHiveXdIney1R0Vx/1prkYL+kABRG0C01NR0cgQXV0aG9yiQEV
AwUQMh93R1cf9aa5GC/pAQEH0gf+JYJ7Vuj0jjJZvLsL0Vn2n/Ny3ZFF4dxnKDIJ
y4+Fdnx6Q8v11Q8VNgzUN15bKKn2SfUZXC6eTJ7JS3T2HKWl6by0I5mQLJNdLBTe
DYzybI5HP+briaGJm9eyrnuhCk0V5Y91GEEUglHRqn0bnK/p+cAccQoet0aZVal7
A4UgFNZqfrU3fN5I/aghcBo0gt0P3mYjzL3eNSuvUU3B5Tc/Xy7hLWGY4N6EAsI5
nwZR38zmpavbEhp1nlnZQbTrDB3zyPltSY+pa/sJ/NH4GcHcg9zi7/jhJSMNtiT
h4XnQner6r1nf8zcsVfGpN87MYlPeWvKBo1kDg0/IZ4aLYgtpg==
=fEDH
-----END PGP PUBLIC KEY BLOCK-----

```

[Back to table of contents](#)

Index of Adaptations

- Adaptation-1 Using bigger culture jars
- Adaptation-2 Using a pressure cooker to sterilize the substrate
- Adaptation-3 Slowing colonization by packing the substrate
- Adaptation-4 Lowering contamination risk by inoculating 1 site
- Adaptation-5 Speeding colonization by using more inoculant
- Adaptation-6 Speeding colonization by using optimum temperature
- Adaptation-7 Speeding colonization by providing more oxygen
- Adaptation-8 Removing the rice cake before 100% colonization
- Adaptation-9 Waiting to remove the rice cake
- Adaptation-10 Checking out the terrarium before use
- Adaptation-11 Use of a higher quality cooler for terrarium
- Adaptation-12 Use of a humidity gauge in the terrarium
- Adaptation-13 Use of a tank heater when using fish tank bubbler
- Adaptation-14 Use of plastic wool to produce finer bubbles
- Adaptation-15 Extra terrariums when using ultra sonic humidifiers
- Adaptation-16 Use of ice-pak to help initiation of pin heads
- Adaptation-17 Adding moisture to the rice cake by injection
- Adaptation-18 Continued drying of shrooms while being stored
- Adaptation-19 Circuit modification to ultra sonic humidifier
- Adaptation-20 Adding moisture reservoir to cake during substrate preparation
- Adaptation-21 Use of a timer to control water droplet Water Droplets and Stimulate Fruiting
- Adaptation-22 Use of home made rice flour to speed colonization
- Adaptation-23 Lowering of contamination rate by Presterilization
- Adaptation-24: Using a 2 1/2 gallon water jug for filtering
- Adaptation-25: Producing contaminate free mushrooms for generating spore prints
- Adaptation-26: Producing a clean spore print from a questionable cap

[Back to table of contents](#)

Adaptation-1: Use of Big Substrate Jars

Normally, 1/2 pint canning jars are used to prepare the rice cake cultures. It is possible to use 1 pint canning jars instead. In fact, in some parts of the country you may have a difficult time finding the 1/2 pint size.

Advantage:

The main benefit to using the larger 1 pint size is that more substrate can be growing mushrooms in your terrarium. The terrariums described in this report typically will hold 6 or 8 cakes. If you want more substrate growing mushrooms, one way to accomplish the goal is to use bigger cakes.

Disadvantages:

There are several disadvantages to using bigger cakes. First, it takes several weeks longer for the fungus to colonize the entire cake. Another disadvantage is that if you suffer from contamination, you will be throwing out more substrate material. Lastly, you need to make sure when you construct your terrarium that you leave a few more inches of space under the drip shield for the cakes to reside. Since they are taller, they will require the drip shield to be placed higher.

You may notice mushrooms trying to grow inside the jar before the substrate is 100% colonized. This is not ideal because you are using up moisture in the cake for something that you won't consume, but it is a fact of

life using the 1 pint jars. It is normal.

[Back to preparation and colonization of substrate](#)

[Back to table of contents](#)

Adaptation-2: Use of a Pressure Cooker to Sterilize

Normally, most people will elect to use a large kitchen pot to sterilize the culture jars. A pressure cooker can be used instead. Instead of letting the substrate jars sit in boiling water for 1 hour, you can place them in a pressure cooker set to 10 or 15 P.S.I for 20 minutes.

One caution. Do not release the pressure until the unit is fully cooled. The substrate in the culture jars will be at 250 F. If pressure is released, moisture will boil out of the substrate.

Advantage:

If you use a pressure cooker, you can sterilize the jars quicker and with more certainty.

Disadvantages:

Pressure cookers cost money. If you already have one, there is no disadvantage. You may as well use it!

[Back to preparation and colonization of substrate](#)

[Back to table of contents](#)

Adaptation-3: Tight Packing of Substrate to Slow Colonization

You can slow the colonization of a jar dramatically by simply packing the substrate material very tightly in the culture jars.

Advantage:

Normally, people want the substrate to colonize as quickly as possible. In the case where more culture jars are being prepared than can fit in the terrarium, it is good to space out the colonization of the jars so that some of the early rice cakes are consumed and spent before the last jars in the batch are ready to be placed in the terrarium. This technique allows you to space out the colonization of your jars so you can prepare more of them at one time and harvest them later than usual.

If you are doing twice as many jars as will fit in your terrarium, pack half of the jars very tightly.

Disadvantages:

The substrate material will compress a little bit when packed tighter. You may have to mix up a little extra substrate material to fill the tightly packed jars to the proper level.

[Back to preparation and colonization of substrate](#)

[Back to table of contents](#)

Adaptation-4: Injection at Only 1 Site

You can inject only one site instead of the usual four sites in the culture jar.

Advantage:

There are two advantages to doing this. First, you use significantly less inoculate. Generally it is not worth while for this reason. The inoculate is not very expensive if you purchase spore syringes. It is virtually free if you prepare your own spore syringes.

The main reason why this is sometimes worth while has to do with contamination. By far, the most likely spot for contamination to enter the culture jar is at the site of the inoculation. If you have a spore syringe that may not be entirely free of contamination, you can increase your probability of keeping the culture free of contamination by only inoculating one site. Note that commercial spore syringes are typically very sterile. If you do nothing to change this fact, it is best to inoculate at four sites in the culture jar.

In order to illustrate the point, assume that the spore syringe has slightly 'dirty' contents but is still viable. Assume any given injection site has a 50% chance of becoming contaminated. If you inject only one site, the culture has a 50% chance of becoming contaminated. If you inject four sites, the culture has a $0.5 * 0.5 * 0.5 * 0.5 = 6\%$ of **NOT** becoming contaminated. If you do everything right, this technique to increase your probability of producing a contamination free culture should not be necessary. However, many people have problems generating sterile spore prints at the start of their cultivating experience and this will help those people continue to generate cultures until they get enough experience. The first time you use a spore syringe that you prepared yourself, you may want to inoculate half of your jars the normal way, and the other half this way. If your spore syringe is just a 'little' dirty, this will give you second chance to grow more mushrooms and prepare a cleaner spore syringe.

Disadvantages:

It will take significantly longer for the jar to become 100% colonized.

[Back to preparation and colonization of substrate](#)

[Back to table of contents](#)

Adaptation-5: Large amounts of Inoculate

You can speed up the colonization of a jar dramatically by simply injecting the substrate material with more inoculate.

If you inject 1 cc of inoculate at each site, you will get many germination's and the cake will colonize significantly faster. You should place the beveled side of the syringe needle against the glass so that the inoculate is coming out of the syringe and heading towards the glass. It should form a thin puddle of liquid between the glass and the substrate. 1 cc of inoculate should produce a puddle several inches in diameter.

Advantage:

Normally, people want the substrate to colonize as quickly as possible. This will help accomplish that goal. Also, the sooner and more fully the cake gets colonized, the less chance there is that contamination will get a foot hold and destroy the cake.

Disadvantages:

This adaptation requires extra inoculate. If you are producing your own spore syringes it is not a factor. A single spore print can produce many (close to 50) spore syringes. If you are purchasing your spore syringes,

you may wish to wait the few extra days to avoid the extra cost of using more inoculate.

[Back to preparation and colonization of substrate](#)

[Back to table of contents](#)

Adaptation-6: 80 Degree Colonization Temperature

The culture jars can be colonized at a temperature higher than room temperature. 80 Degrees F. is ideal. Slightly higher is OK.

There are several easy ways to accomplish this. If you have a floor heater with a pilot light and it is summer time (so the heat is not going to come on), you might be able to put the cakes in a shoe box and set them on the unit. The top of your water heater might be a good candidate. You can fill a cake pan half way with water and put a submersible fish tank heater in the water set to 80 degrees. Then simply put the jars in the cake pan. However you choose to do this, make sure the temperature does not get above 90 degrees. Check out the heat source before you subject your cakes to it.

Advantage:

Colonizing the substrate at 80 degrees F. is the ideal temperature for several reasons. First, the mycelium will grow faster and the substrate will be colonized in the shortest amount of time. Secondly, when the cakes are removed from the jars, initiation of fruiting is enhanced by shocking the cakes with a temperature drop, lower CO2 levels, and light.

If you plan to have your terrarium at normal room temperature, then colonizing at 80 degrees will help you initiate a massive flush of mushrooms when you place your cakes in the terrarium.

Disadvantages:

None.

[Back to preparation and colonization of substrate](#)

[Back to table of contents](#)

Adaptation-7: More Oxygen for Colonization

The culture jars can be given more oxygen during colonization. This is done by inverting the jars so that the lid is down.

Advantage:

As the CO2 builds up, growth of the fungus slows down. Indeed, the mycelium benefits from increased CO2 during its vegetative growth stage, but eventually it gets too high for optimum growth. If you invert the jars, the CO2 can drain out and is replaced by fresh air. This will speed the colonization of the substrate.

Disadvantages:

There are several disadvantages to this. First, the rice cakes normally shrink a little bit while in the jars and when you invert the jars they will slide down a little bit. This will create a vacuum and pull some air into the jar. This air could have contaminants that get a foot hold in the uncolonized portions of the cake.

The second reason you will want to avoid doing this is the initiating of the fruiting process is triggered by

three things. A drop in temperature, a drop in the CO2 level and light. You may confuse the fungus and inhibit a massive flush when you take the cake out of the jar. You will still get a crop, but it may take longer to consume the cake.

[Back to preparation and colonization of substrate](#)

[Back to table of contents](#)

Adaptation-8: Taking the Rice Cake Out of the Jar Before it is 100% Colonized

The partially colonized substrate can be removed from the jar if the uncolonized portions of it are cauterized. Remove the cake from the jar and heat a nail head red hot using a propane torch or burner on a gas stove. Brand the entire uncolonized area.

Advantage:

Nothing will grow on the uncolonized, cauterized portions of the rice cakes. If you need to remove a cake early from the jar this will keep contamination from having a place to get a foot hold. There are very few good reasons to exercise this adaptation. The reason the authors have included it is sometimes growing cycles overlap and you want to start a new culture in every jar you have. If you birth the rice cake early, you have an extra jar to prepare cultures in. One other reason for doing this is travel. If your leaving on a trip (one where you will be out of town) and your cake will be overly colonized by the time you get back, you can use this adaptation to birth the cake early and move it to the terrarium.

Disadvantages:

This is dangerous. It is asking for trouble. First, you are assuming that you can inhibit growth of contaminants on the uncolonized portion of the cake. The bigger the area that is uncolonized, the more risky this assumption is.

Secondly, the process assumes that when the cake is removed from the jar it has sufficient networks in place to provide the nutrition needed for the fruiting process. If you take the cake out too early, this may not be the case.

[Back to preparation and colonization of substrate](#)

[Back to table of contents](#)

Adaptation-9: Waiting to Remove Rice Cake From the Jar

The colonized substrate does not need to be removed from the culture jar immediately after it is 100% colonized. You can wait until primordia form on the substrate.

Advantage:

There are a number of reasons why you might want to delay the 'birthday' of the rice cake. You may not have room in the terrarium or be planning a trip where you won't be around to maintain the terrarium. Also, waiting gives the mycelium more time to fully develop its network throughout the substrate and can result in larger flushes.

Disadvantages:

The continued development of the mycelium network will take place at a slower rate in the jar than it would with lots of oxygen available.

[Back to preparation and colonization of substrate](#)

[Back to table of contents](#)

Adaptation-10: Checking Out Terrarium Prior to Removing Rice Cake

The colonized substrate does not need to be removed from the culture jar immediately after it is 100% colonized. You can wait until primordia form on the substrate.

Advantage:

There are a number of reasons why you might want to delay the 'birthday' of the rice cake. You may not have room in the terrarium or be planning a trip where you won't be around to maintain the terrarium. Also, waiting gives the mycelium more time to fully develop its network throughout the substrate and can result in larger flushes.

Disadvantages:

The continued development of the mycelium network will take place at a slower rate in the jar than it would with lots of oxygen available.

[Back to preparation and colonization of substrate](#)

[Back to table of contents](#)

Adaptation-11: Use of a Coleman Cooler instead of a Styrofoam Cooler

A fancy, nicer, plastic cooler can be used instead of a Styrofoam cooler.

Advantage:

The nicer, plastic coolers typically have more space in them so they can hold more rice cakes. Also, it is nice to have a cooler with a hinged top that simply flips up and allows access easily. Lastly, the plastic coolers are more durable than Styrofoam coolers. If you plan to use the terrarium a lot, go ahead and use a plastic cooler from the start.

Disadvantages:

Cost is one disadvantage. Another disadvantage is the plastic coolers are more difficult to modify for use as a growing chamber than the Styrofoam coolers.

[Back to construction of basic growing chamber](#)

[Back to table of contents](#)

Adaptation-12: Adding a Humidity Gauge to the Terrarium

A humidity gauge can be added to the terrarium. Especially for Styrofoam coolers, it is easy to cut out a window in the side of the cooler and insert a combination humidity/temperature gauge. The gauge should be put below the drip shield so that it is showing the actual conditions where the mushrooms are growing. In reality, the conditions will not vary much inside the terrarium, but there is no reason to add inaccuracy. The gauge can be glued in place with silicon glue. Make sure the vents in the gauge are only open to the inside of the terrarium and not the outside world. The combination gauge can be got very inexpensively at any department store.

Check all the gauges on the shelf. Most likely, some will deviate greatly from the rest. You want to pick one that seems to be accurate! Bare in mind that usually there are several different brands of gauges available. Check and see what various gauges from different brands are reading. Use some common sense to eliminate the obviously inaccurate gauges. Even so, you are making the assumption that at the high end of the humidity spectrum the chosen gauge will be accurate. Remember that absolute accuracy is not so important as knowing the relative conditions inside you terrarium over time. Even if you gauge is off a little bit, it will tend to be off in the same direction all the time. The easiest way to use a gauge during the growing process is to know what it used to read during previous growing cycles and keeping close to that reading. If a problem does develop, it will provide a clue which direction you need to move.

Advantage:

A humidity gauge is very helpful during the growing cycle, but it takes up valuable real-estate inside the terrarium. This gets it out of the way inside the terrarium and makes it easy to see the state of the terrarium with out messing around inside the terrarium.

Disadvantages:

None.

[Back to construction of basic growing](#)

[Back to table of contents](#)

Adaptation-13: Use of Fish Tank Heater to Raise Humidity

If you are using the fish tank bubbler system to create humidity in your terrarium, you can use a submersible fish tank heater to help raise the humidity. You can place the fish tank heater in the water and use it to raise the water's temperature 10 or 15 degrees F. over ambient. This will make it easier for the air bubbling through the water to absorb moisture, thus raising the humidity. The higher you set the temperature of the heater, the more humidity you can get. You should be careful not to allow the inside temperature of the terrarium to get above 80 degrees F. In order to effectively use this adaptation, your terrarium will need to be in a cool location.

Advantage:

You will be able to generate an extra 5% of humidity over ambient by using this adaptation.

Disadvantages:

You will increase the temperature inside your terrarium some by doing this. You can minimize the temperature increase by using a container to hold the water that is well insulated. You want the water warm, but you don't want heat leaking any more than necessary into the terrarium.

[Back to Method 2, Using a Fish Tank Bubblier](#)

[Back to table of contents](#)

Adaptation-14: Use of Angel Hair to Raise Humidity

If you are using the fish tank bubblier system to create humidity in your terrarium, you can place angel hair or anything else that will slow the bubbles rise in the water container. Simply pack it into the container. This will increase humidity by several percent. Ideally, you want to slow the bubbles but also split them into smaller bubbles. Some plastic versions of steel wool for use washing dishes work well. Steel wool would work well except that it will rust and get nasty.

Advantage:

You will be able to generate an extra 1% or 2% of humidity over ambient by using this adaptation. The smaller the bubbles are and the more time they spend in the water, the greater the benefit.

Disadvantages:

None.

[Back to Method 2, Using a Fish Tank Bubblier](#)

[Back to table of contents](#)

Adaptation-15: Supporting Extra Terrariums with the Ultra Sonic Humidifier

First, build an extra Growing Chamber. Then on one of the 2 liter coke bottles, poke an extra hole. Insert a grommet and make this bottle the last stage for drying the air. Even the most basic ultra sonic humidifier can feed more than one terrarium with sufficient quantities of humid air to keep everything in the ideal range for the fungus.

Advantage:

You get twice the growing area for your mushrooms. Your crops can be twice as big. Alternatively, you can use one terrarium for older cakes. Older cakes are significantly more likely to become contaminated and pose a threat to the other cakes in the terrarium. Moving older cakes to the second terrarium drastically reduces your chances of a crop failure.

Disadvantages:

You need to build an extra Growing Chamber, and it takes up a little space.

[Back to construction of Ultra Sonic support system](#)

[Back to table of contents](#)

Adaptation-16: Use of an Ice-Pak to Initiate Fruiting

You can keep the terrarium's temperature between 80 and 95 degrees F. If you have a terrarium setup that uses an ultra sonic humidifier, you can place a reusable, frozen Ice-Pak in the Terrarium. This will cool everything down and let the rice cakes slowly shift through the fruiting temperature range. Note that everything else must be right. The rice cake must have a fully developed mycelium network and there must be light. The Ice-Pak should be placed between 1/4 and 1/2 inch from the rice cakes. A flat Ice-Pak will work, but if you have the option, get one that is designed to slip into the center of a six-pak. It will have circular indents molded into each side and it will conform to the shape of the rice cakes better. If everything was ready, you should see pin heads develop 3 or 4 days after you perform this adaptation. If you don't see any develop after 3 or 4 days, you can repeat this operation again. The networks may not have been developed full enough and the few days since the last attempt may have been enough time to change this fact.

Advantage:

You can still initiate prolific flushes with the terrarium above the normal temperature range. The optimum temperature for growing mushrooms is higher than what is necessary to initiate new mushrooms and is between 80 and 90 degrees F. This adaptation can let the cultivator grow at the maximum rate, and still produce new mushrooms on the cakes.

Disadvantages:

The Ice-Pak will lower the humidity in the terrarium. Mostly, this is an issue when you have mushrooms on cakes that are part way through the growing cycle and not ready to harvest. They will usually survive the bad growing conditions for the six hours it takes the Ice-Pak to initiate fruiting, but they will suffer for it. You need to have an ultra sonic humidifier setup on your terrarium. Nothing else will be able to keep the humidity high enough. You can turn the humidity control up a little, but you will have to continue to adjust it down as the Ice-Pak loses its cool. If too much moisture forms on the cakes, it will prevent the initiation of pin heads and that was the whole purpose of this operation.

[Back to the Growing Cycle](#)

[Back to table of contents](#)

Adaptation-17: Adding Moisture to the Rice Cake

After a cake has produced several mushrooms you can add moisture to it. Flame sterilize a 3/16 inch drill bit. Let it cool. Use it to drill a hole at the center of the cake. You can do this by hand. You do not need a drill. Do not go all the way through the cake, but drill a deep reservoir into the cake. Cut a plastic straw to 4 inches in length. Insert the straw 1/2 inch into the hole. The straw should fit tightly in the cake. Straws from McDonalds are larger than most and work well. They seal well and hold more water. Fill the straw with water daily. A 10 cc. syringe works well to fill the straws with water. You should wait to drill the hole until the cake has produced some mushrooms because the inside of the rice cake is not colonized as quickly as the outside. Also,

there is sufficient moisture in the cake at the start so there is no need to add water immediately.

Advantage:

The rice cake will produce many more mushrooms than it would have without adding moisture. Using this adaptation allows the nutrients in the rice cake to be almost totally consumed before the cake is exhausted.

Disadvantages:

Care should be taken when drilling the hole because there is no way to monitor for contamination inside the hole. Also, you will need to add water on a daily basis.

[Back to the Growing Cycle](#)

[Back to table of contents](#)

Adaptation-18: Continued Drying of Mushrooms During Storage

You can place a small glass with a small amount of desiccant in the long term storage bag to continue to extract moisture from the mushrooms. A shot glass with 3/4 of an ounce of desiccant is sufficient to keep the humidity very low in the long term storage bag. A larger glass that is more stable might be a better choice in order to avoid an accident of spilling the desiccant inside the bag.

Advantage:

The mushrooms will continue to dry and their preservation is enhanced.

Disadvantages:

You will need to be careful not to knock the glass over and spill desiccant in the storage bag. This is only suitable if you can leave the bag in a stationary location.

[Back to Drying and Preservation of Mushrooms](#)

[Back to table of contents](#)

Adaptation-19: Reducing Output Of Ultra Sonic Humidifier

The output of the ultra sonic humidifier can be reduced by changing the circuitry. Almost all ultra sonic humidifiers use a 5 K-ohm or 10 K-ohm potentiometer to control the output. By adding a 5 K-ohm or 10 K-ohm resistor in series with the potentiometer, the original 'low' setting becomes the new 'high' setting. The humidity output can be turned down even lower than originally possible. Simply cut the wire going to the potentiometer and solder a similar sized resistor (available at Radio Shack) in series. You may need to set the humidity control above the minimum setting once you make this modification.

Note that this adaptation is mutually exclusive with Adaptation-21. If you try to combine them, it won't work.

Advantage:

This drastically reduces the suspended water particles emitted by the humidifier. However, the big advantage is that the humidifier uses significantly less water. It is possible to fill up the humidifier and leave on a trip for 10 days without having to add water.

Disadvantages:

Complexity is the major disadvantage. The above instructions are deliberately technical. If reading them doesn't give you enough information, don't attempt to do this. Find someone to help you. It is very easy and straight forward for someone that is handy with a soldering iron to accomplish.

[Back to Method 3 of Terrarium Construction](#)
[Back to table of contents](#)

Adaptation-20: Providing a Moisture Reservoir in the Substrate

A reservoir for moisture can be built into the cake while packing the jars with substrate material. Start with an empty jar and tamp 1/4 inch of substrate material in the bottom. Next, position a magic marker or some other object with a cylindrical shape and a diameter of about 3/4 inch in the center of the jar. Fill the jar as normal. Next, remove the object and fill the bore with damp vermiculite. Lastly, pack 1/4 inch of substrate material over the entire jar, sealing the damp vermiculite inside the cake.

The damp vermiculite can be mixed separately from the substrate material. Use about 1 cup of vermiculite and 1/3 cup of water. This should produce enough damp vermiculite for a dozen 1/2 pint culture jars.

After the cake has fruited, occasionally inject water into this reservoir. The easiest place to inject is the position of the cake that used to be at the center of the bottom of the jar. Just insert a syringe filled with sterile water and inject water until it is full.

In case you are wondering, the substrate material can't be injected with water directly. The rice flour and vermiculite form a very tight seal and it is next to impossible to inject water. Even if you do manage to inject water, it doesn't spread through the cake. Having this reservoir filled with damp vermiculite gives the mycelium network access to a lot of moisture.

The easiest way we have found to implement this adaptation is to cut the bottom off of a 10 cc syringe and press the bottom of the syringe into the wet vermiculite several times. This will load the syringe with wet vermiculite. Then place the syringe in the culture jar and pack the substrate around it. Use the syringe's plunger to hold the wet vermiculite stationary while you remove the syringe. Tamp an additional 1/4 inch of substrate material over the entire surface of the jar.

Advantage:

This adaptation will dramatically extend the longevity of the cake. The cake's yield are normally limited by the amount of moisture in the cake. This procedure allows you to replace moisture as it is consumed by mushroom growth. In general, you will double the total output of the cake compared to not implementing this adaptation.

Disadvantages:

It is a little bit of extra work to prepare the jars this way. Also, there is a need to be careful to use sterile water when injecting moisture during the growing phase. There is no way to check for contamination introduced inside the cake by injecting water.

[Back to preparation and colonization](#)
[Back to table of contents](#)

Adaptation-21: Use of a Timer to Control Suspended Water Droplets and Stimulate Fruiting

The ultra sonic humidifier can be placed on a timer to control the amount of suspended water droplets that are released into the terrarium. Because the humidifier is turned on and off the humidity in the growing chamber will rise and fall. There is starting to be some evidence that this helps stimulate fruiting.

This document used to recommend using a timer that gives control on a minute by minute basis. These timers are becoming increasingly difficult to locate and more expensive. To accomodate this, there has been a strategy shift on this adaptation. Find a timer that lets you limit the 'On' cycle to 15 minutes. Intermatic makes two version that sell for under \$15. They are model numbers SB811C and TB811C. They are available in the electrical section of Home Building Centers. You may also find them in the hardware section of a department store.

Since the shortest amount of time the timer can switch on is 15 minutes, it is important to make sure the cakes do not get water droplets forming on them in this much time. In general, the condensation filter chambers should be set up identically to the normal humidified chamber setup. You just may not need as many filter stages since the humidifier will not be running steady.

The other parameter you need to set is how tight to seal the chamber. You need to make sure the chamber's humidity does not drop too far during the 'Off' cycle of the timer. Typically, the 'Off' cycle is at least an 1.25 hours. (On the Intermatic timers, this coresponds to every third switch being up.) Ideally, you want the humidity to fall to 85% by the end of the cycle. (If your chamber seals tightly, you may be able to go every fourth or fifth switch).

Advantage:

There are several advantages to using a timer.

- Less drying stages are needed for the humidifier. The output can be piped more directly into the terrarium.
- The humidity in the chamber will be moving up and down which seems to stimulate fruiting.
- Water consumption by the humidifier is automatically reduced making unattended operation more possible.

Disadvantages:

Cost and availability are the major disadvantages.

[Back to Building Terrarium with ultra-sonic humidifier](#)

[Back to table of contents](#)

Adaptation-22: Use of a Home Made Brown Rice Flour

This idea is from: AN165023@anon.penet.fi

Rather than use brown rice flour available at a health food store, you can grind your own from long grain brown rice. Simply put the dried rice into a coffee grinder or a blender and let it chew the rice into a chunky flour. You will need to increase the water from 1/4 cup per 1/2 pint jar by 1 and 1/2 tablespoons. The chunky home ground flour absorbs a little more water than the normal flour.

Advantage:

Cost is one benefit, but that is not the reason this adaptation is useful. Using home ground flour will speed the colonization of the substrate. It has been reported that a 1/2 pint jar can be 100% colonized in 11 days if fresh spores are used and the jar is kept at 85 degrees F. during colonization. Note that this is the current record, and most jars will take a bit longer, but overall, the colonization time period is reduced.

Also, the home made brown rice flour seems to yield much more consistently and produce slightly more mushrooms per cake than store bought flour.

Disadvantages:

Extra effort.

[Back to preparation and colonization of substrate](#)

[Back to table of contents](#)

Adaptation-23: Lowering the Contamination Rate by Presterilization

The raw ingredients of the substrate can be sterilized separately to eliminate nearly all of the contaminants. Spread the vermiculite and rice flour evenly into separate cake pans and bake in a preheated oven at 300 degrees F. for 20 minutes. While these are baking, boil a large bowl of water in for 10 or 15 minutes. Use these materials to mix the substrate. It is still necessary to sterilize the jars filled with substrate.

Advantage:

Nearly all of the possible contaminants in the raw materials will be eliminated. The sterilization of the substrate after you mix and prepare the substrate will only need to address any new contamination that you added during that process. The sterilization of the mixed substrate will be much more guaranteed. You should experience a lower contamination rate. This adaptation is particularly useful if you are not using a pressure cooker to sterilize the culture jars. Boiling the culture jars only gets them up to a temperature of 212 degrees F. This adaptation provides an opportunity to eliminate contaminants that require a higher temperature to kill them.

Disadvantages:

Extra time and effort.

[Back to preparation and colonization of substrate](#)

[Back to table of contents](#)

Adaptation-24: Using a 2 1/2 gallon water jug for filtering

This idea is from 'Dangerous Dan'. A large, 2 1/2 gallon water jug from store bought water can be used instead of 2 liter coke bottles. These large jugs can be used for all stages of the filter, but if only using one, it should be the first one after the humidifier.

Advantage:

Using these water jugs provide a few advantages.

- Because of their size, they don't need to be emptied as often.
- They have a simple to operate valve that can be used to ease draining.
- Their shape makes it easier to stack neatly along a shelf.
- Because of their large volume, less filtering stages are needed.

Disadvantages:

The worst disadvantage is the fact that these containers are typically not transparent and if used for all the stages it is difficult to see how much fog is in the system.

[Back to construction of Ultra Sonic support system](#)

[Back to table of contents](#)

Adaptation-25: Insuring the Sterility of Caps Used for Spores

If you are going to use a cake to generate spores, you can insure that the caps stay free of contaminates. When you birth the cake from the culture jar, set it on a clean wash cloth in the terrarium. Place a large glass jar over it and seal it to the wash cloth. A large peanut butter jar is usually perfect. You need to have enough room inside the jar for the mushroom to grow to maturity. Humidity will be able to leach through the wash cloth and surround the cake, but air currents will not be present and the cap should be relatively free of contaminates. This setup assumes the floor of the terrarium has a wire mesh to support the cakes.

Advantage:

A much cleaner cap will be available for making prints. This will lower the chances that contamination is introduced into the process.

Disadvantages:

Extra effort. Extra space in the terrarium.

[Back to Making a Spore Print](#)

[Back to table of contents](#)

Adaptation-26: Producing a clean spore print from a questionable cap

Setup everything the way you would normally to generate a spore print. Keep an eye on where in the process the cap is. After a cap has been dropping its spores for three or four hours, you can change the plate on which the spores are being deposited. Simply discard the initial plate. The new plate will be contain a much cleaner spore print than would have been possible with only one plate.

Advantage:

A much cleaner print will be generated. If contaminants get on the gills of the mushrooms, as the cap starts to drop spores, the first spores contain most of the contaminants. By discarding the initial spores, you will end up with a cleaner spore print.

Disadvantages:

You need to catch it at the right time.

[Back to Making a Spore Print](#)

[Back to table of contents](#)

Revision History

- **05-20-05 - Minor Update by Erowid**

Minor wording change in first paragraph of "The Author's First Trip" section to make it clear that the negative effects of LSD were just things they'd been told, not actual effects.

- **10-02-96 - Last Major Revision by Author**
